

# IMO OptiLine

*Magnetic coupling for a leak-free future*



# IMO OptiLine Pumps

## IMO'S THREE SCREW PUMP

Since its inception over 75 years ago, IMO AB has been dedicated to providing high quality pumps designed to meet customer needs and specifications.

With changing applications, industry standards, and fluid parameters, the time has come for a new solution that is safer, requires less maintenance and has a lower life-cycle cost. To meet this challenge, IMO AB has developed the OptiLine series of leak-proof three screw pumps.

## COMPACT DESIGN

The IMO three screw pump and its driver are assembled with a connecting frame. This ensures good alignment and a compact unit with a small footprint.

## BUILT-IN SAFETY VALVE

All IMO three screw pumps designed to handle outlet pressure of up to 16 bar are equipped with an internal, adjustable pressure relief valve. This is preset just above the required system pressure to ensure safe operation.

## DEVELOPMENT OF A LEAK-FREE PUMP

A packing box, a mechanical seal or a lip seal are the most common methods for decreasing leakage around a rotating shaft extending through the wall of a pump. Such seals are lubricated by the pumped liquid and a slight leakage can always be expected. Certain liquids may disturb the proper function of the seal, causing severe leakage.

Changing between different oil types (for example, high viscosity HFO to low viscosity MGO) will put extra stress on a conventional seal and typically leads to severe leakage.

In order to meet regulations and customer demand for a leak-free pump, IMO AB has developed a sealless solution – the IMO OptiLine series. There is no shaft extension into the open air and thus no need for a conventional seal. Instead, power is transmitted into the pump over a magnetic coupling and the pump shaft is completely enclosed by a static, non-magnetic metal can. A number of extremely strong rare earth permanent magnets affixed to the pump shaft inside the can are driven by a similar set of permanent magnets on the driver shaft outside the can. The attraction force between the two sets of magnets ensures a perfectly synchronous rotation of the two shafts with a high power transmission capability.

The IMO OptiLine series is therefore the recommended solution for applications where seal leakage would otherwise cause hazards, system downtime, costly vetting inspections or significant maintenance costs.

## BENEFITS

In addition to the standard benefits of an IMO three screw pump, there is no costly downtime. The IMO OptiLine offers a leak-free operation that is significantly more environmentally friendly due to improved safety and low maintenance cost. This is especially recommended for exposed applications where safety is an issue.

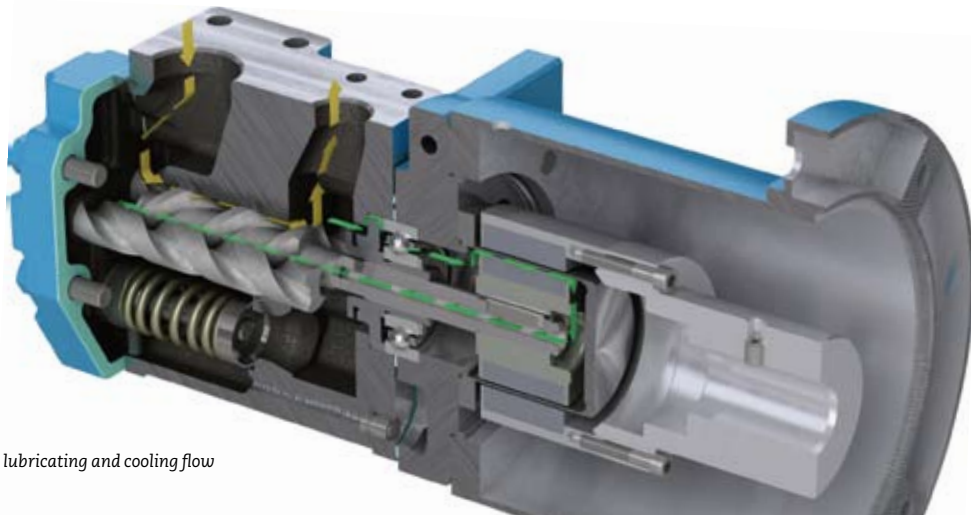

Internal lubricating and cooling flow

OptiLine pumps meet requirements for low viscosity (down to 1.4 cSt) according to ISO 8217:2005 and low sulfur (0.1%) as stated in EU/SECA 2005-33-EC. All while maintaining the same high efficiency.

### SAVINGS

The cost of spare parts and maintenance are significant contributors to the life cycle cost. Since there is no wear on the parts of a magnetic coupling configuration, the maintenance cost for such a pump is minimal. Return on investment for an IMO OptiLine, compared to a corresponding pump with a mechanical seal, is often less than two years.

### FULLY ENCLOSED

With the OptiLine design, torque is transmitted from the driver to the pump without any mechanical contact.

The design features a completely sealed-off pump consisting of an inner rotor with permanent magnets coupled to the pump and sealed by a non-magnetic can. On the atmospheric side, an outer rotor with permanent magnets is coupled to the driver.

As this design does not have any sliding contact seals, there is simply no way for the confined liquid in the pump to escape.

### NO NEED FOR EXTERNAL COOLING

The magnet assembly is designed to withstand temperatures of up to 350°C without jeopardising function. In order to disperse the heat generated by viscous friction and eddy current losses in the coupling as well as lubricate the bearing, a small fraction of the main pump flow is diverted into the can of the magnetic coupling and then returned to the pump inlet. Thus, there is no need for any external cooling or holes in the connecting frame that could allow debris from the outside to cause wear on the magnets or seal can.

### STEAM TRACING

On cold, start-up conditions high viscosity could cause the rated torque for the coupling to be exceeded. The IMO OptiLine pumps have a way to allow steam tracing, adjacent to the magnets, and connection to the steam system aboard a ship.

### Technical data – IMO OptiLine

MODEL	ACE	ACG	UNIT
CAPACITY	0.6–10.8	10–70	M3/H
DIFF. PRESSURE	16	16	BAR
VISCOSITY	1.4–1500	1.4–1500	CST
TEMPERATURE RANGE	-20 TO +180	-20 TO +180	°C
MAX. SPEED	3600	3600	RPM
VALVE BLOCK	YES	NO	

### SOLAS REQUIREMENT II-2 REGULATION 4

*As much as possible, oil fuel lines should be arranged far away from hot surfaces, electrical installations or other sources of ignition and should be screened or otherwise suitably protected to avoid oil spray or oil leakage.*

### OPTILINE MOUNTED ON A VALVE BLOCK

A valve block can be utilised to save space as well as reduce the cost of pipe work and installed components when the pump is installed with a stand-by. The new IMO Valve Block features a design in which each component and its operation has been evaluated to meet different operation modes.



IMO Valve Block configuration

### UPGRADING

The IMO OptiLine pump is ideal for upgrading a pump system equipped with an older generation of IMO pumps or other oil pump models. With few exceptions, it is virtually a drop-in replacement between the IMO standard three screw and an OptiLine pump. This keeps the cost of piping and restructuring to a minimum.

### SUMMARY

For rough duty pumping such as Heavy Fuel Oil and orimulsion applications, IMO OptiLine pumps are the optimal solution for eliminating the risk of oil leakage that could be hazardous to the environment, human safety or process function.

Meeting the requirements for low viscosity (down to 1.4 cSt) according to ISO 8217:2005 and low sulphur (0.1%) as stated in EU/SECA 2005-33-EC, the OptiLine pump is the new standard for all fuel handling systems on the market today.

Using an OptiLine pump means that you are able to change between media from 1.4 cSt MGO to 1500 cSt HFO without any need for manual operation. This unique ability combined with the nitril carborated coating gives you a future-proof pump ready for whatever lies ahead.

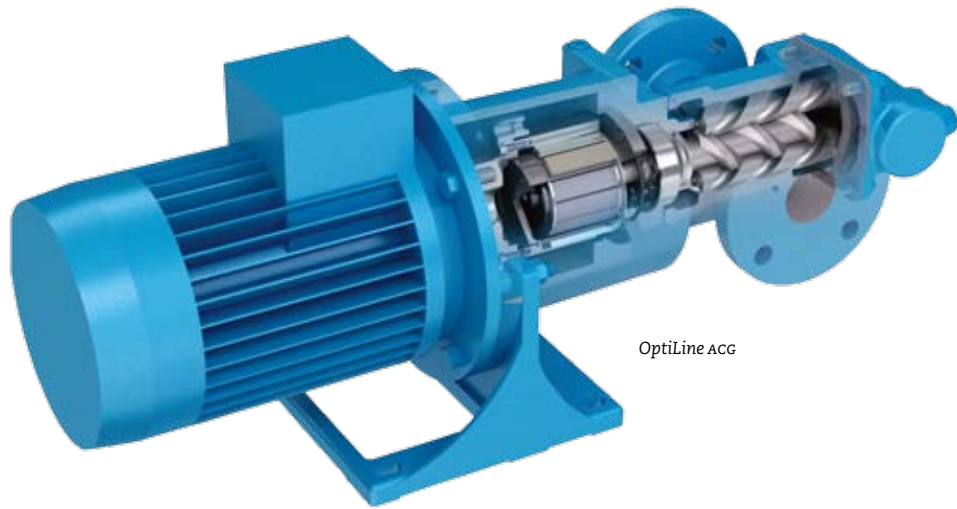

OptiLine ACC

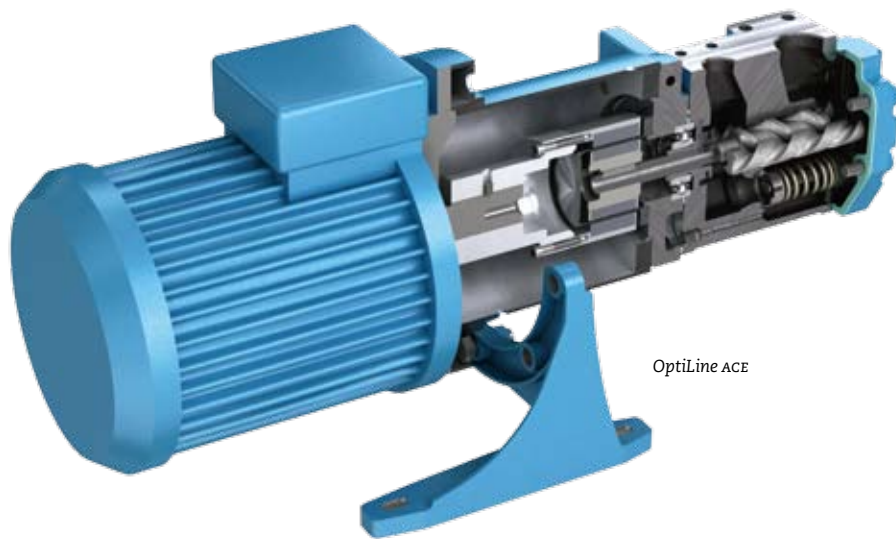

OptiLine ACE

