

## Maintenance and Service Instruction

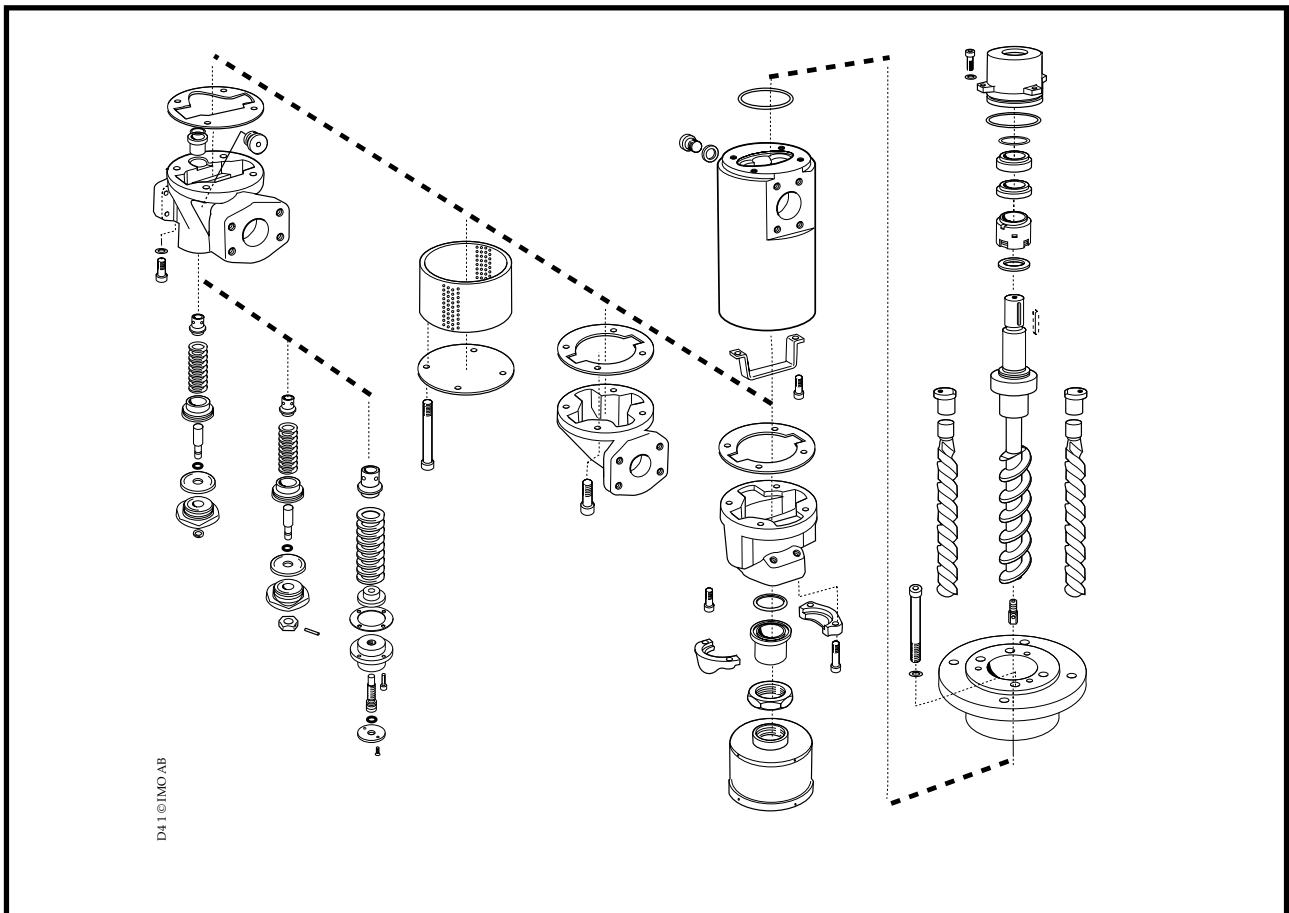

This instruction is valid for all D4 pump models shown on page 2

Contents	Page
List of components	2
Exploded view	3
Ordering code/Service intervals	4
Inspection of rotors/Sectional view	5
List of tools/Inspection of shaft seal	6
Dismantling/Reassembly	7
Pressure relief valve	11



**Before commencing any work, read this instruction carefully!**  
**Failure to comply with these instructions may cause damage and personal injury!**

For more information about the pumps identification code, technical data and performance we refer to the D4 Product description.

For more information about the pumps installation, start-up and trouble shooting we refer to the IMO Installation and Start-up instruction for medium and high pressure pumps.

## List of components

Valid for all D4 pumps in sizes: D4 025/032/038/045/052/060/070; Rotor diameter and Generation: L2/K2/N2

With version codes:

L } R } B } E }  
 I } V } J } P }  
 T } T }

The version code is composed of the letters in the 4 columns. Also valid for pump options A101.

*Example of pump designations std: D4 025L2 LRBE  
 option: D4 038 K2 LVBP A 101*

Pos No	Denomination	Qty	G011	G012	G050	G057	P.E.	Note
101	Power rotor (CCW-rot.)	1	x				(x)	
102	Power rotor (CW-rot.)	1		x			x	
113	Key	1	x	x			x	
1030	Valve	1	x	x			x	
124	Retaining ring	1					x	13
124A	Support ring	1					x	13
124B	Washer	1					x	13
139	Balancing washer	1						
139A	Retaining ring	1					x	13
201	Idler rotor (CCW-rot.)	2	x				(x)	
202	Idler rotor (CW-rot.)	2		x			x	
376	Balancing bush	2	x	x			x	
382	Screw	4						7
391	Plate	1						7
395	Support plate	1					x	
395A	Screw	2					x	
401	Pump body	1					x	
423	O-ring	1						10
427	Split flange	2						10
427A	Weld stud	1						10
428	Screw	4						10
428A	Washer	4						10
451	Screw	4					x	
451A	Washer	4					x	
453	Screw	4						9
453A	Washer	4						9
455	Screw	4						2
463	Plug	1					x	5
463A	Washer	1				x	x	5
489	Strainer	1						8
491	Nut	1						1
497	Valve seat	1						11
497A	O-ring	1						11
501	Front cover	1					x	
506	O-ring	1				x	x	
507	Washer	1					x	
509	Shaft seal	1			x		x	
520	Cover	1					x	
520A	O-ring	1				x	x	
521	Screw	3					x	
521A	Washer	3					x	
551, 5510	Inlet chamber	1						9
556	Gasket	1				x		9
557	Plug	1						11
601	Valve cover	1						11
602	Washer	1						11

### Explanations:

G011 = Rotor set, CCW-rotation  
 G012 = Rotor set CW-rotation (std)  
 G050 = Shaft seal  
 G057 = Joint kit  
 P.E. = Pump element G102 (CW) or G101 (CCW)

Pos No	Denomination	Qty	G011	G012	G050	G057	P.E.	Note
605	O-ring	1						11
608	Valve spindle	1						6
608A	Retaining ring	1						3
608B	Valve spindle	1						4
608C	Nut	1						4
608D	Pin	1						4
609	Washer	1						2
609A	Screw	2						2
611	Washer	1						2
612	Regulating nut	1						12
614	Valve piston	1						11
615	Spring	1						11

Note 1 Valid for sizes 025-060 xxJE

2 Only for xxBP size 060-070

3 Only for xxBP size 025-032

4 Only for xxBP size 038-052

5 Not for xxBP

6 Valid for xxBP size 025-032, 060-070

7 Valid for xxTE

8 Valid for xxTE, xxJE

9 Not for xxTE

10 Valid for xxJE

11 Valid for xxBP

12 Valid for xxBP sizes 025-052

13 Valid for sizes 025

## Exploded view

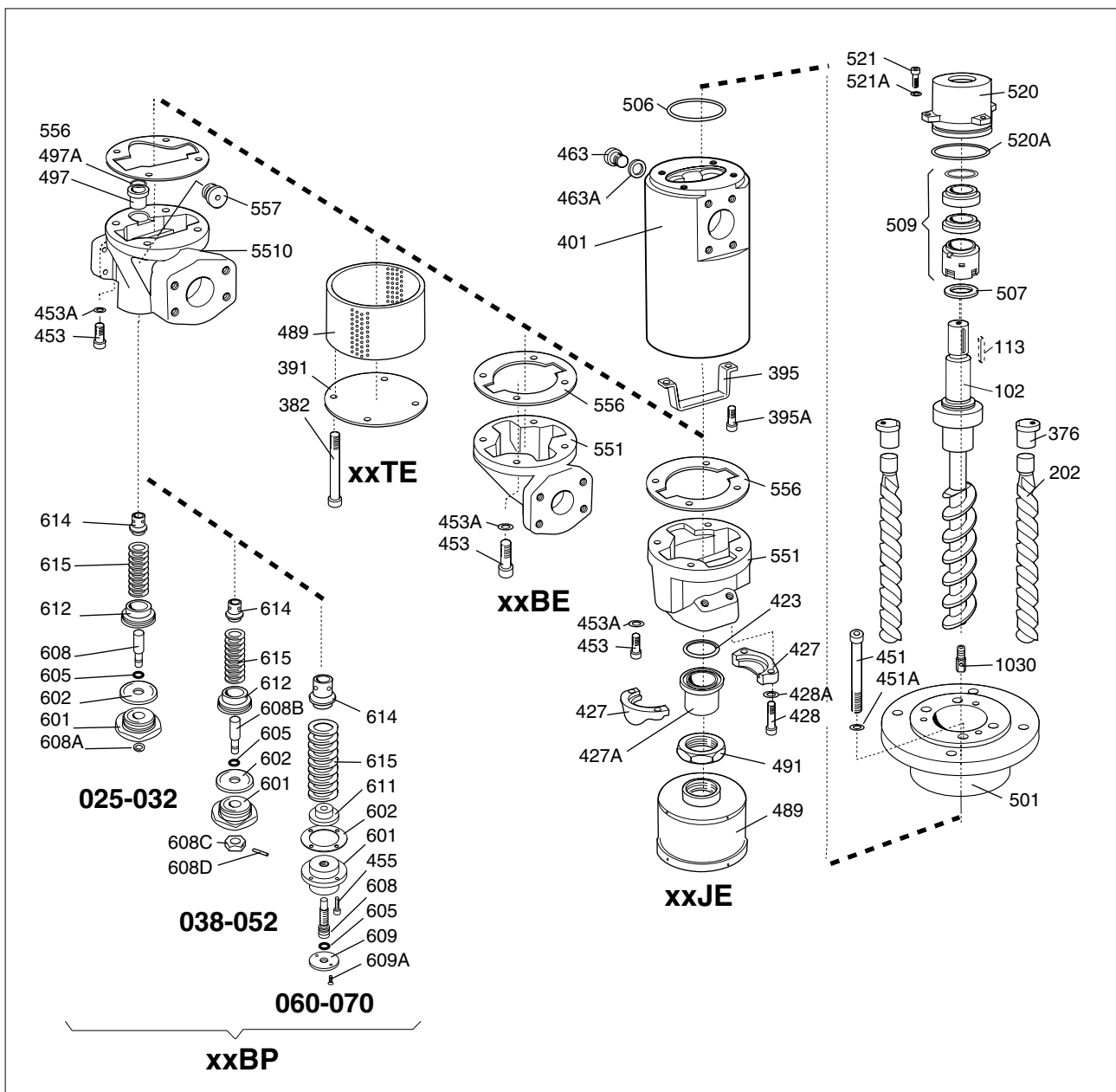

Fig. 1

# Ordering code

Pos no	Spare part sets	Part numbers, sizes							
		025	032	038	045	052	060	070	
G011	Rotor set (CCW-rot.)	Contact IMO AB							
G012	Rotor set (CW-rot.)	163410	150425	163428	166926	150433	186569	186585	
	"	–	–	146332	154534	186551	186577	186593	
G050	Shaft seal	N-lead	128314	128314	120873	124610	124610	128728	128728
		K-lead	143859	143859	190336	190338	190338	142299	142299
		L-lead	168906	168906	172726	172049	170449	168914	168914
G057	Joint kit	xxxE	185819	185827	185835	185843	185850	185868	185876
Major kit (pump element) different versions		Contact IMO AB							

## Recommendation for maintenance

Every shut down for service of a plant is costly. The time for repair should therefore be limited to a minimum which can be accomplished by keeping a spare pump. The changed pump can later be repaired at a suitable place and can then be used as a spare pump.

For maintenance the following spare parts kits are recommended:

Kit	Contents	To be used for
G057	Gaskets, O-rings, etc	Dismantling of the pump.
G053	Minor kit G057+shaft seal G050	Normal scheduled inspection.
G054	Major kit, pump element G102 (CW) or G101 (CCW)	Repair after damage or greater wear.
Ordering example:		For IMO pump D4
Rotor set G012		025N2 LVBE
Shaft seal G050		Part no. 163410
		Part no. 143859

## Service intervals

The intervals for inspection and replacement of wear parts vary greatly with the properties of the pumped liquid and can only be determined by experience.

All internal parts of the D4-pump are lubricated by the pumped liquid. Pumping a liquid containing abrasive materials, or a liquid that is corrosive, will significantly reduce service life and call for shorter service intervals. Wear in the pump may be indicated by:

- Vibration
- Noise
- Loss of capacity
- Reduction in flow or pressure
- Leakage

In installations where unplanned shut downs must be avoided, it is advisable to have a complete pump available for replacement, should any malfunction occur. Furthermore we recommend planned inspection and overhaul at regular intervals, not exceeding 3 years.

It is recommended always to have the spares included in the minor spare part kit available.

 Before any maintenance work, ensure that the driver is deenergized and the pump hydraulically isolated.

 Connecting and disconnecting of electric cables must be done only by personnel authorized to do such work.

 If the pumps operating temperature exceeds 60°C let the pump cool off before any service, maintenance or dismantling work is commenced to avoid burn injury.

 All work carried out on the pump has to be performed in such a manner that risks for personal injury are observed!

 When handling liquids that may harm skin use gloves and/or protective clothing.

 When handling liquids which may involve fire hazards appropriate precautions to avoid danger are to be taken.

 In case of failure for a system with elevated pressure, fluid jets may cause injury and/or damage.

 Oil leakage may make the floor slippery and cause personal injury.

# Inspection of rotors

If the pump is not able to maintain the pressure inspect the rotor parts by following the instructions in fig. 10-11.

Internal clearances in the pump, which are vital for its proper function, may have been affected by wear. Acceptable wear can be determined only by experience of the actual application. As a rule of thumb the following max clearance values may apply:

- Between rotor and bores or bushings: 0.2 mm
- Between rotor flanks: 0.2 mm

For light duties (low pressure, medium viscosity) even bigger clearances may be acceptable whilst for low visc. /high pressure duties the limit will be lower. Also check if there are major scratches on these parts. If you find any of these problems, replace the whole pump element, otherwise reassemble the pump by following the instructions in fig. 12 and forward.

# Sectional view

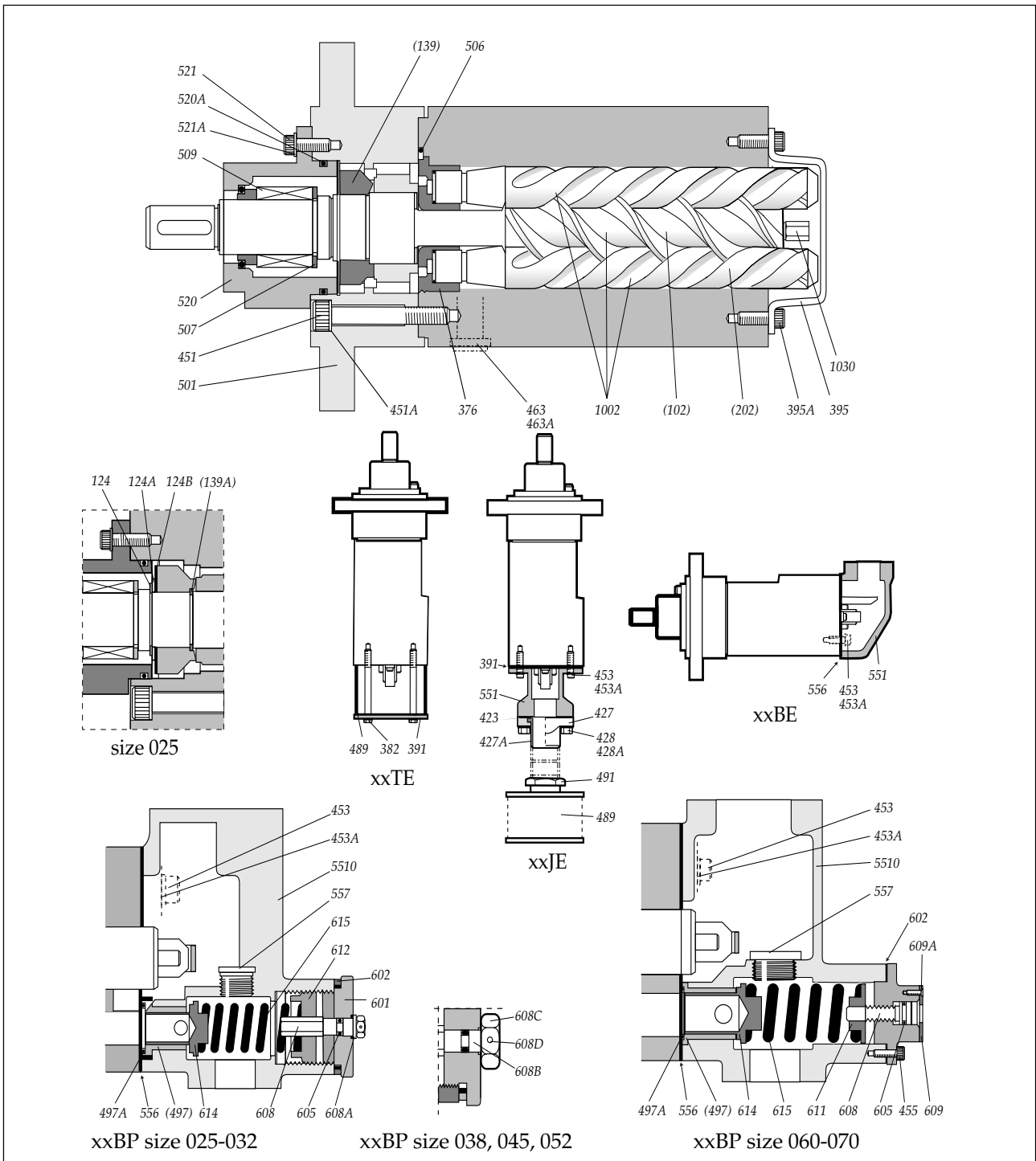

Fig. 2

# List of tools necessary for dismantling/reassembly

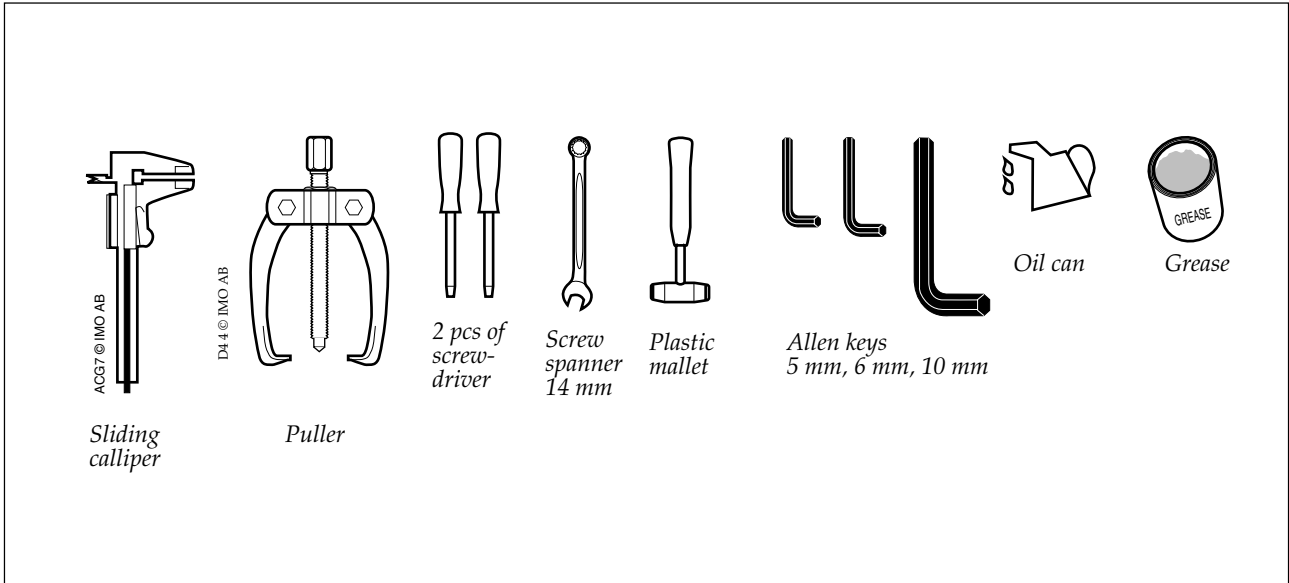

Fig. 3

## O-rings

All O-rings found to be hard or damaged shall be replaced.

## Inspection of shaft seal

As the seal faces of a mechanical shaft seal are lubricated by the fluid, a certain leakage will always be present. Up to ten drops per hour can be considered as acceptable. An external visual inspection of the pump is advisable at least every two days to assure that the shaft seal is not leaking

too much. Excessively leaking shaft seals should be changed without delay, as the leakage normally will grow worse and cause additional damage.

Follow the instructions in the dismantling/reassembly session.

When working with a shaft seal, cleanliness is of utmost importance. Avoid touching the seal faces. If necessary, the seal faces should be cleaned immediately prior to assembly, using a dust free cloth and clean solvent.

Never use grease on the seal faces.

## Shaft seal – assembly drawing

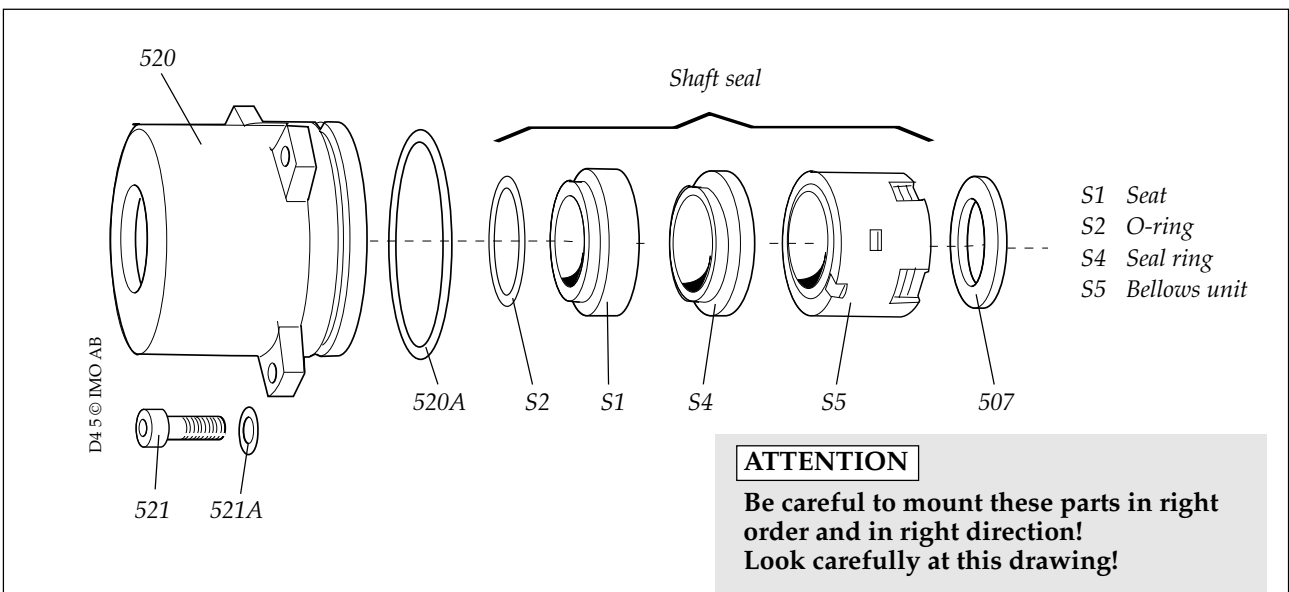

Fig. 4

# Dismantling

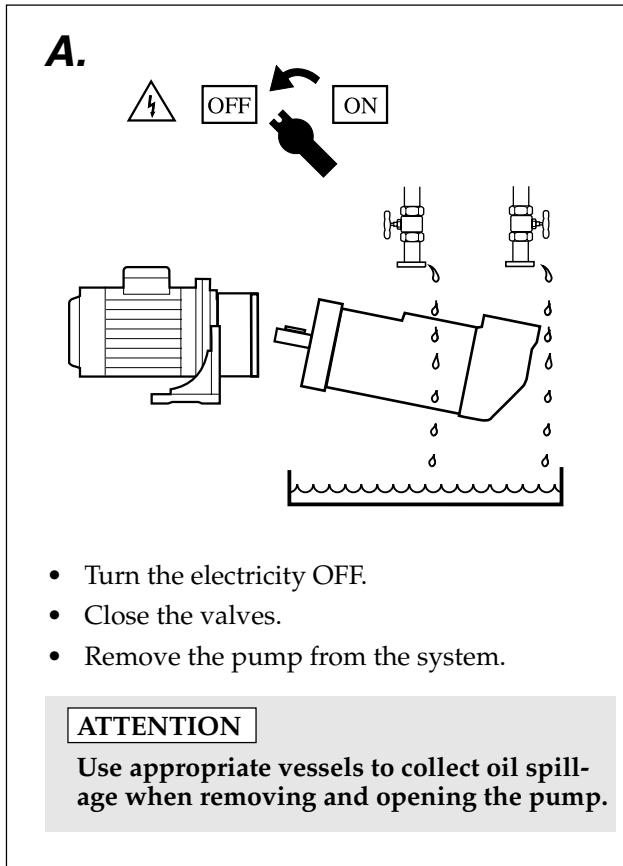

Fig. 5

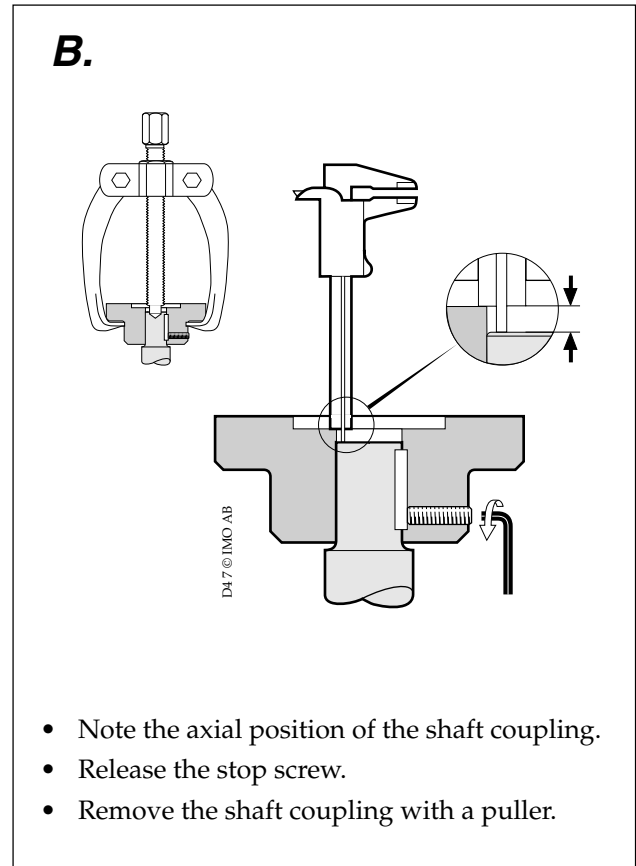

Fig. 6

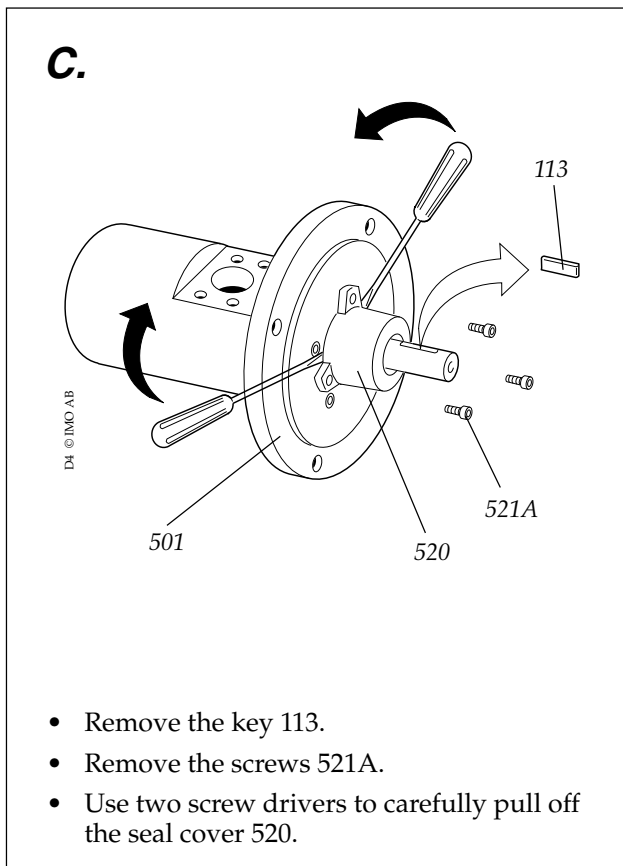

Fig. 7

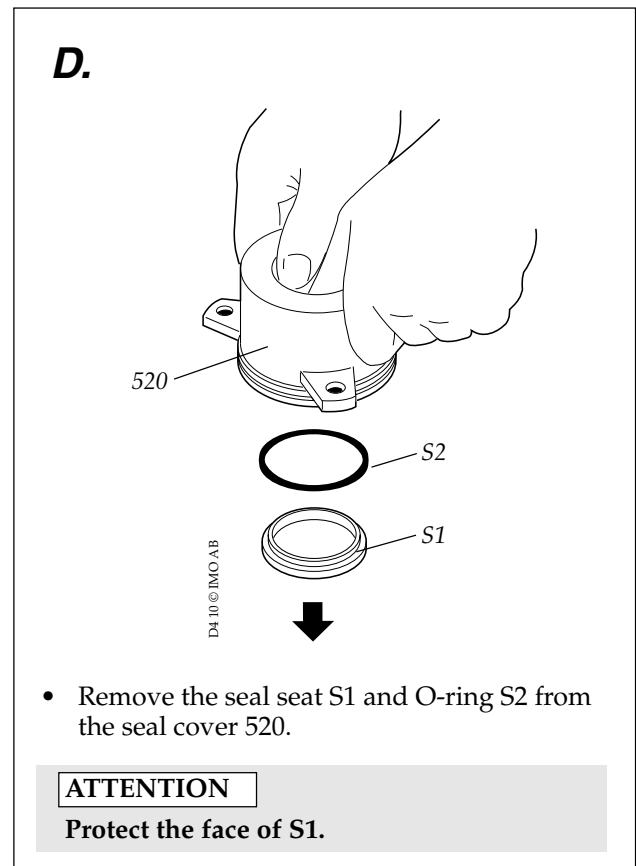
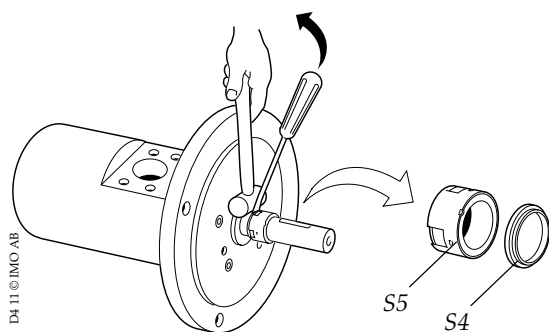

Fig. 8

**E.**



- Remove the shaft seal bellows unit S5 and the seal ring S4.

**ATTENTION**

Protect the face of S4.

Fig. 9

**F.**

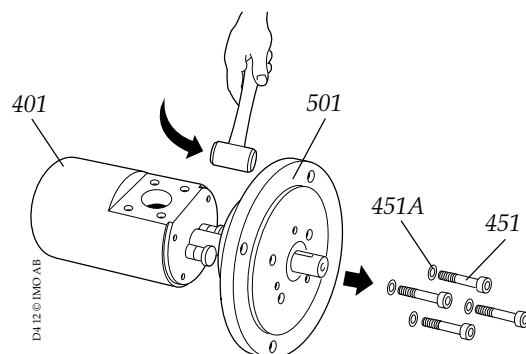

- Remove the screws 451 and washers 451A.
- Carefully loosen the front cover 501 from the pump body 401 with a plastic mallet.
- Remove the front cover 501 and rotor set in one move.

Fig. 10

**G.**

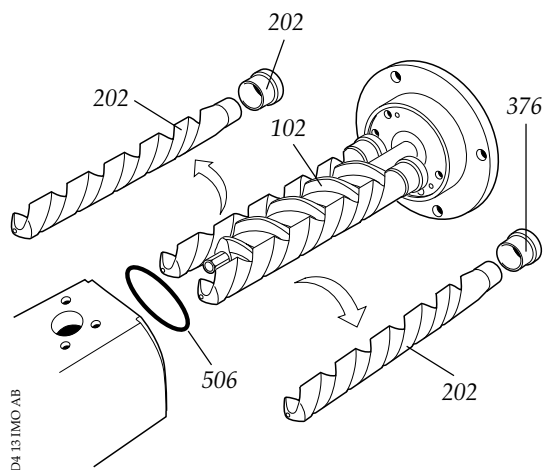

- Inspect the rotors, balancing bushes 376 and O-ring 506 by separating them.

Fig. 11

**H.**

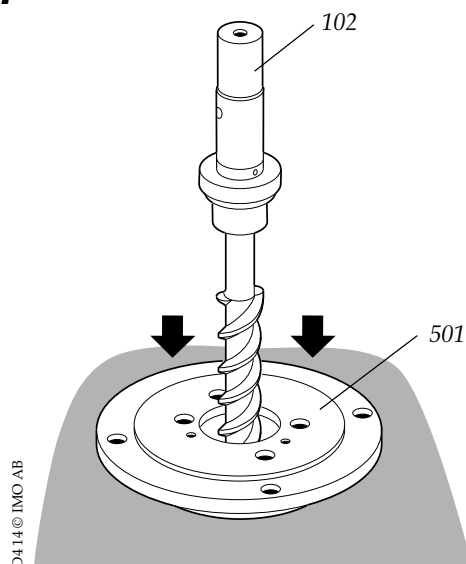

- Separate the front cover 501 and the power rotor 102.

**ATTENTION**

Be careful not to make scratches in the surfaces of the balancing piston bore.

Fig. 12

# Reassembly

## A.

- Check prior to assembly – by mounting the balancing bushes (376) in the pump body (401) and by placing a ruler over their end faces – that the balancing bushes extend 0,0 - 0,25 mm above the end face on the pump body. If not, replace the balancing bushes.

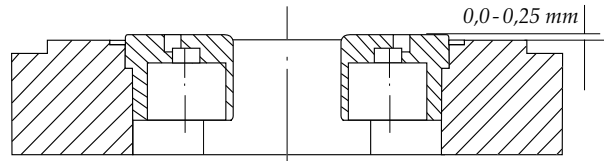
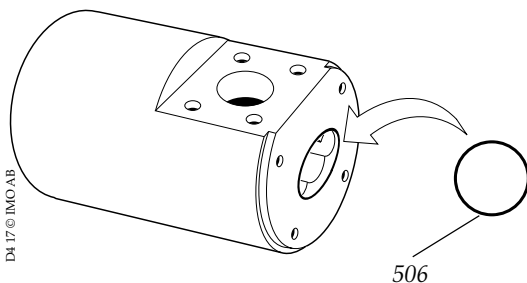

Fig. 13

## B.



- Fit the O-ring 506.
- Lubricate it with bearing grease if it is difficult to keep it in place.

## C.

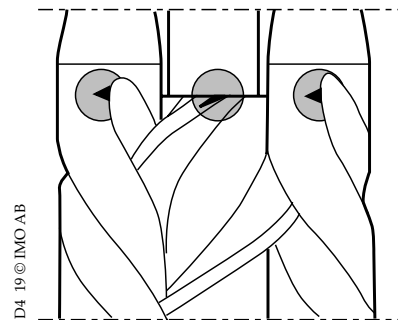

- A nick has been filed on the power rotor thread on the outer diameter at the discharge end. This marked power rotor thread should be fitted into the female thread on the idler rotors marked in the same manner.

Fig. 14

Fig. 15

## D.

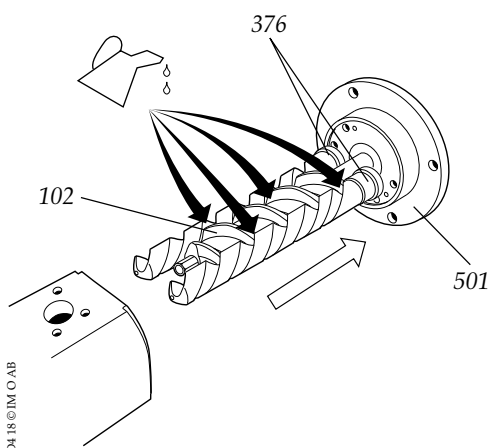

- Fit the power rotor 102 in the front cover 501. (See fig. 12).
- Lubricate the rotor set.
- Assemble it including balancing bushes 376.

## E.

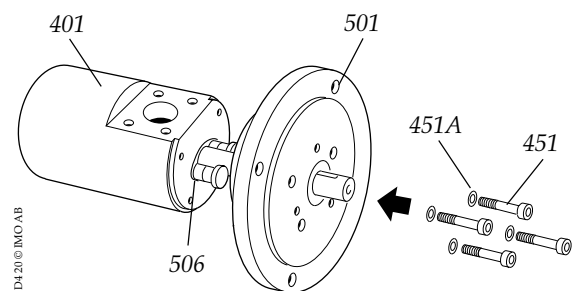

- Carefully insert the rotor set into the pump body 401.
- Watch the position of O-ring 506.
- Make sure the bolt holes match.
- Fit the screws 451 and the washers 451A. Tight the screws crosswise.

Fig. 16

Fig. 17

**F.**

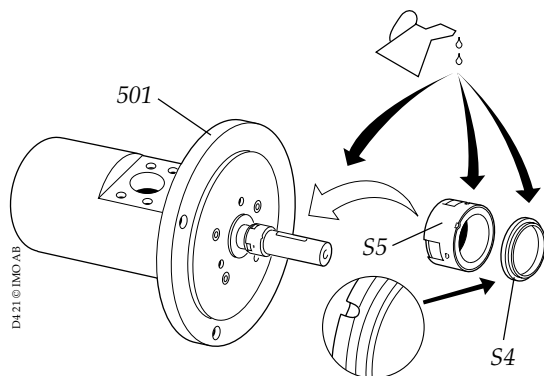

- Lubricate the power rotor shaft, the bellows unit S5 and the seal ring S4.
- Fit the bellows unit S5 into the front cover 501.
- Fit the seal ring S4. Note the position of the drive notches on S4 and S5. They need to fit together.

Fig. 18

**G.**

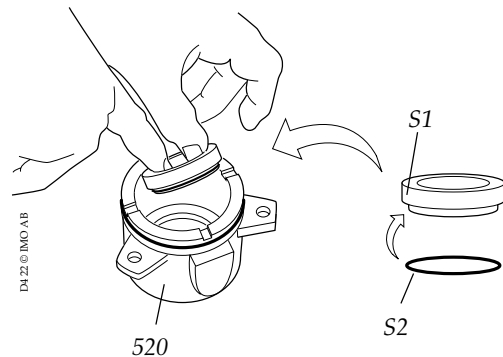

- Fit the O-ring S2 in the seal seat S1.
- Fit the seat S1 in the seal cover 520.

**ATTENTION**

**Do not use dirty fingers on the seal face.  
Keep it clean and dry.**

Fig. 19

**H.**

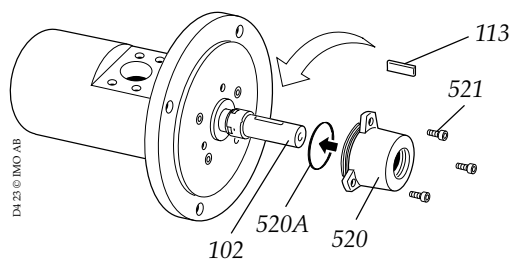

- Lubricate and fit the O-ring 520A on the seal cover 520. Fit the seal cover onto the power rotor shaft 102.
- Fit the screws 521 and tighten them carefully.
- Fit the shaft key 113.

Fig. 20

**I.**

- Fit the coupling half back into place and lock with locking screw.
- Check that the axial position is the same as before dismantling. (See fig. 6).
- Put the pump back into the system and proceed according to instructions under "Start-up" in the installation manual.

Fig. 21

# Pressure relief valve D4xxBP

## Dismantle

- Remove the valve unit from the pump.
- Release spring force by turning the spindle CCW.

### 025-052

- Loosen cover 601 and remove it together with the nut by using the valve spindle.
- Remove retainer 608A or C.
- Pull out the valve spindle (608 or 608B) and replace the O-ring (605).

### 060-070

- Remove cover (601) by removing screws (455) and remove spring washer (611).
- Remove screw (609A) and washer 609.
- Unwind the spindle (608). Replace the O-ring (605).
- Remove spring (615) and valve piston (614).
- Replace valve piston if it is damaged.
- If the valve seat is damaged the whole inlet chamber (5510) has to be replaced.
- Reassemble in reversed order.

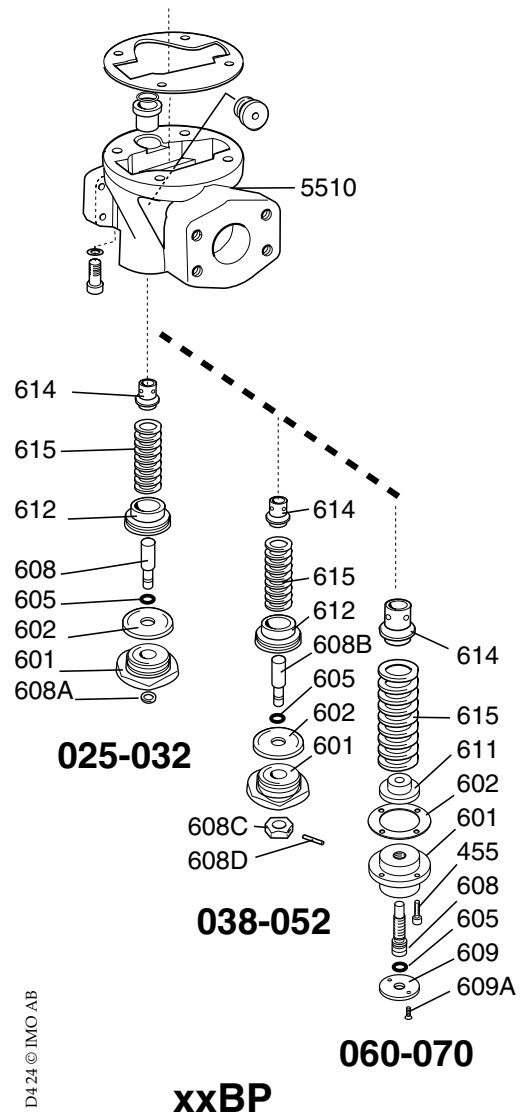

D424 © IMO AB

Fig. 22



A Member of the  
COLFAX PUMP GROUP

**[www.imo.se](http://www.imo.se)**

---

**IMO AB:**

P. O. Box 42090, SE 126 14 Stockholm, Sweden

Telephone: +46 8 50 622 800, Telefax: +46 8 645 1509