

### Installation and Start-up Instruction

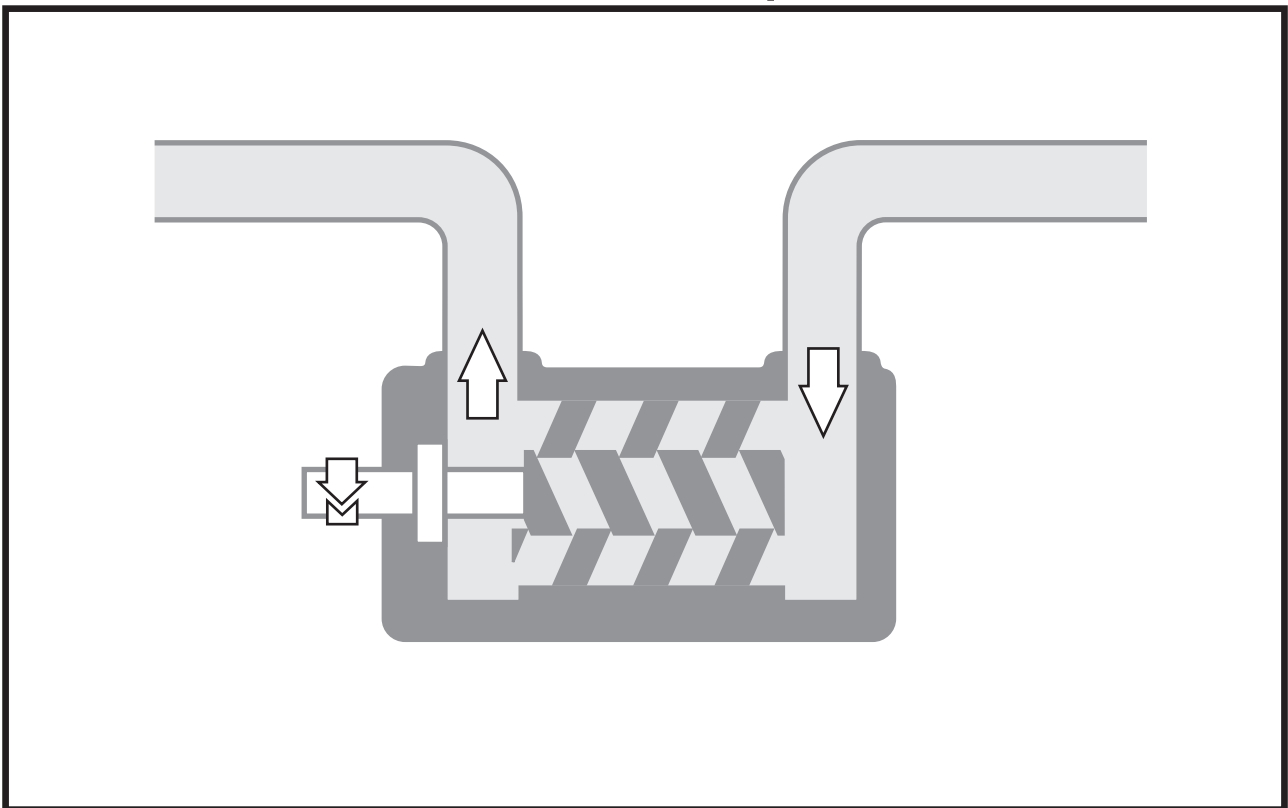





This instruction is valid for all standard low pressure pumps: LPD, ACD, ACE, LPE, ACG/UCG, ACF/UCF, LPQ and ABQ	
Contents	Page
Pump identification	2
Installation	3
Start-up	8
Trouble shooting	10

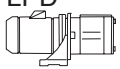
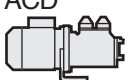

**Before commencing any work, read this instruction carefully! Failure to comply with these instructions may cause damage and personal injury!**

These instructions are valid for all low pressure pumps as specified in the Pump identification chart below.

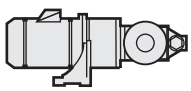
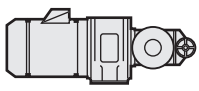
# Pump identification

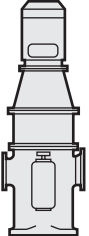
Pump name	Size (1)	Rotor lead (1)	Design modification	Material pump-body (1)	Shaft-seal design (1)	Mounting (2)	Valve (3)	Also valid for option	Comments
LPD 	015 } 020 }	N	1	I	V	B	P		Pumpunit without shaft coupling
ACD 	025	L } N }	6	I } N }	V } T }	B	P		Pumpunit without shaft coupling
ACE 	025 } 032 } 038 }	D } K } L } N }	3	N	V } T } Q }	B	P	A101	
LPE 	025 } 032 } 038 }	D } K } L } N }	3	N	V } T }	B	P	A101	
ACG/UCG 	045 } 052 } 060 } 070 }	D } K } N }	7	I } N }	V } T }	B } F }	E } P }	A101 A327 A020 A385	
ACF/UCF 	080 } 090 } 100 } 110 } 125 }	K } L } N }	4 } 5 }	I } N }	R } V }	B } F }	E } O } P }	A020 A084 A087 A101	O = max 10 bar
LPQ 	100 } 110 } 125 } 140 }	L } N } P } J }	1	I } N }	R } T }	Y	P		
ABQ 	160	B } L } N }	5	I	R	Y	O } P }	A328	O = max 5 bar

- (1) See Product description or Service instruction for specified pump model
- (2) B = Flange mounting  
F = Foot mounting  
Y = Vertical foot mounting
- (3) E = Without valve  
G = Valve with external return  
O = Valve with internal return for reduced pressure range  
P = Valve with internal return for total pressure range

## Option

- A020 Pump with surface treated casing(s)  
A084 Pump with lifetime greased ball bearing  
A087 Pump with CCW-rotation and lifetime greased ballbearing  
A101 Pump with CCW-rotation, when not standard  
A327 Pump with Tuning®  
A328 Pump with Tuning®  
A385 A101 + A327

#### Identification of safety instructions

Non compliance of safety instructions identified by the following symbol - could affect safety for persons.



Safety instructions where electrical safety is involved, are identified by:



Safety instructions which shall be considered for reasons of safe operation of the pump or pump unit and/or protection of the pump or pump unit itself are marked by the sign:

**ATTENTION**

# Installation

**BEFORE COMMENCING ANY WORK, READ THIS INSTRUCTION CAREFULLY!**

Design limitations and technical data for each pump are found in the **Product description**.

Installation of IMO AB low pressure pumps does not require special skills. However, these instructions presume that the work is carried out by experienced fitters.

**Maintenance and service instructions**, which are specific for each pump are presented in a separate document.

 **Failure to comply with these instructions may cause damage and personal injury!**

## Transport and storage

Always protect the pump against ingress of water and other impurities. Store the pump in a clean, dry and warm environment. The pump is delivered with the internals oiled and with protective covers over the pipe connections and drain openings. These covers should remain in place for as long as possible during the mounting and installation procedure but must be removed before start up.

 **All work carried out on the pump has to be performed in such a manner that risks for personal injury are observed!**

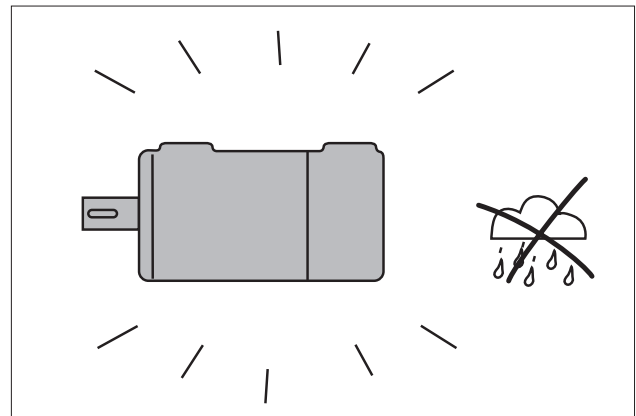
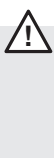

Fig. 1 Clean and dry environment.

## Lifting of pump

 **All pumps should be lifted with straps securely attached to the pump or pump unit, so that the center of gravity is located between the straps in order to avoid tipping of the pump.**

Use two eye bolts (M 20) securely fastened to the front cover for pumps LPQ and ABQ. Pump and connecting frame are lifted together using two eye bolts securely fastened to the top of the connecting frame. (Thread dimension is M 16, except for frame size 600, where it is M 20).

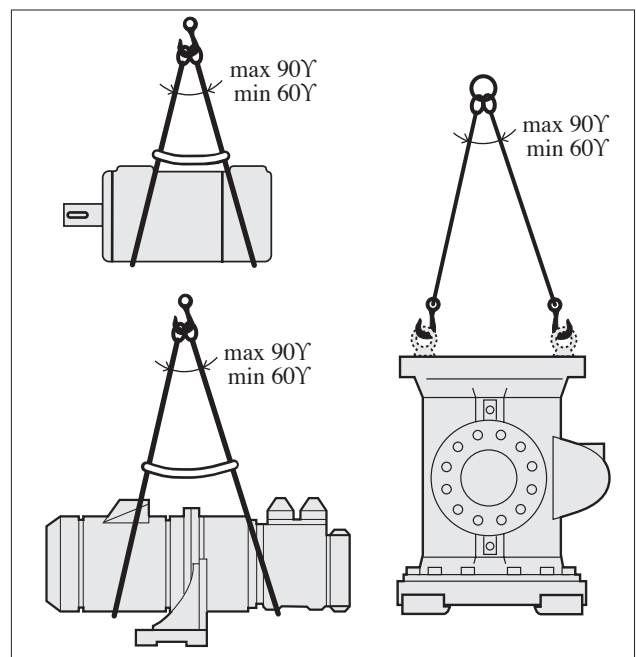

Fig. 2 Lifting of pump

Lifting of the complete pump unit with the lifting device attached to the motor, should be avoided as the motor's lifting provisions may not be able to carry the combined weight of the pump and motor.

**⚠ Lifting a complete pump unit, using slings or hooks attached to the pump or connecting frame may be dangerous since the centre of gravity of the pump unit may be higher than the points of attachments.**

## Mounting

The pump must be securely mounted on a firm stable foundation and positioned so that it is easily accessible for inspection and servicing.

Provisions for collecting oil spillage when servicing the pump should be considered.

### ATTENTION

The installation must always be designed to minimise damage. Should an operational or functional failure occur. E.g. precautions should be considered to collect oil spillage due to a broken pipe or pump housing, to stop pump operation if overheating should occur or if the oil volume is below a minimum tank level.

## Alignment and shaft couplings

The pump shall be connected to its driver via a flexible shaft coupling. Pumps of type ACG/UCG and ACF/UCF may also be driven via gears or pulleys as specified in the Product Description, provided the radial forces are kept within the specified range.

An angular misalignment of  $0.1^\circ$  corresponds to approx. 0.2 mm deviation/100 mm.

The coupling and alignment shall be selected not to transmit any axial or radial loads on the shaft ends. IMO AB standard couplings shall have a distance between the coupling halves as per table, fig 4. the coupling halves shall be secured by lock screws.

For other types of couplings, please refer to respective maker's manual.

**⚠ When fitting the shaft coupling, do not use a hammer or similar as this may damage the ball bearing and shaft seal. Use some kind of press tool.**

**⚠ When handling liquids that may harm skin use gloves and/or protective clothing.**

**⚠ When handling liquids which may involve fire hazards appropriate precautions to avoid danger are to be taken.**

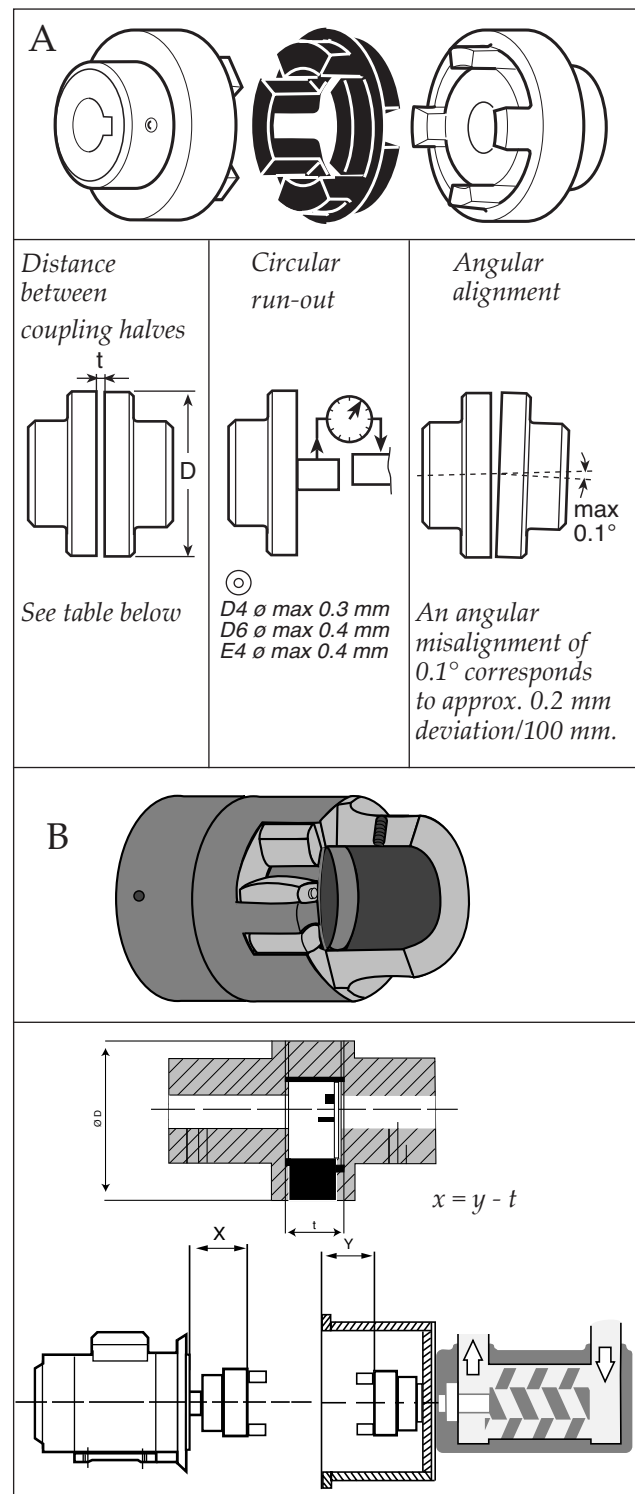

Fig. 3 Alignment of the IMO AB standard coupling

Outer diameter of coupling (D mm)		Distance between coupling halves (t mm)		Outer diameter of coupling (D mm)		Distance between coupling halves (t mm)
A	B	A	B			
50	26	2.0	8	148		3.5
67	40	2.5	16	168		3.5
82	55	3.0	18	194		3.5
97	65	3.0	20	214		4.0
112	80	3.5	24	240		4.0
128	95	3.5	26			

Fig 4. Distance between coupling halves. (IMO AB standard coupling)



Measures shall be provided to avoid accidental contact with the rotating shaft coupling. Any installed coupling guard shall permit easy access to the pump shaft for maintenance and inspection of the pump bearing and seal housing.

## Pipe connections

The pipe work shall be installed and supported so that no pipe stresses are transferred to the pump body.

The pipe work should be tight in order to avoid leakage and infiltration of foreign particles and/or air.

Shut off valves should be installed in both suction and discharge pipes, so that the pump can be hydraulically isolated.

## Suction line

The suction pipe should be designed so that the total pressure drop, measured at the pump inlet flange, does not exceed the suction capability of the pump.

Make a proper calculation of the suction line including components such as valves, strainer, pipe bends etc. Generally, the pressure drop in the suction line should be as low as possible, which is achieved if the suction pipe is short, straight and has a suitable diameter.

The velocity in the suction line should be kept in the range 0.5 - 1.2 m/s. For L.O. circulating systems, we recommend to keep it as low as possible.

The suction line must be equipped with a port that allows filling the pump before start.

## Discharge line

The discharge line should be dimensioned to keep the velocity in the range 1 - 3 m/s.

## Deaeration

In installations with negative suction head, where the pump might be started against a pressurized system, a deaeration pipe with an orifice (2-3 mm recommended) has to be installed. The deaeration pipe should be connected to the outlet pipe's highest point.

This must also be installed when the pump is used as an stand-by pump.

For direct driven pumps the alignment between pump and motor shafts must be kept within the following limits:

	Max run-out (mm)	Max angular misalignment (degrees)
Type LPD and ACD	(n/a short coupled)	
Other types	0.3	0.1

Fig 5.

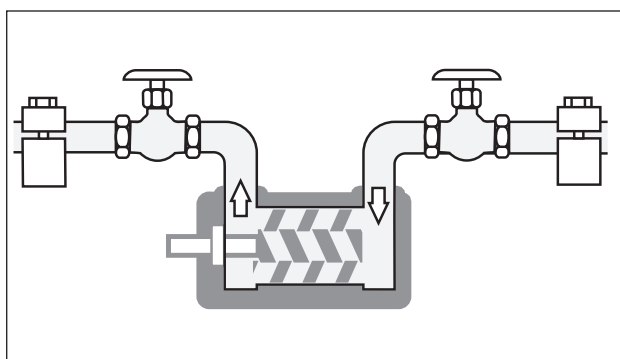

Fig. 6 Pipe connections

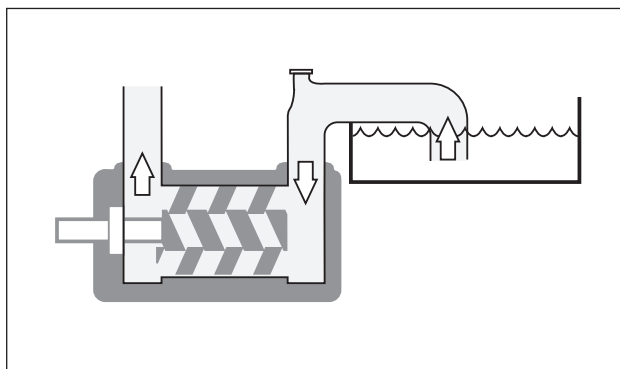

Fig.7 Suction line

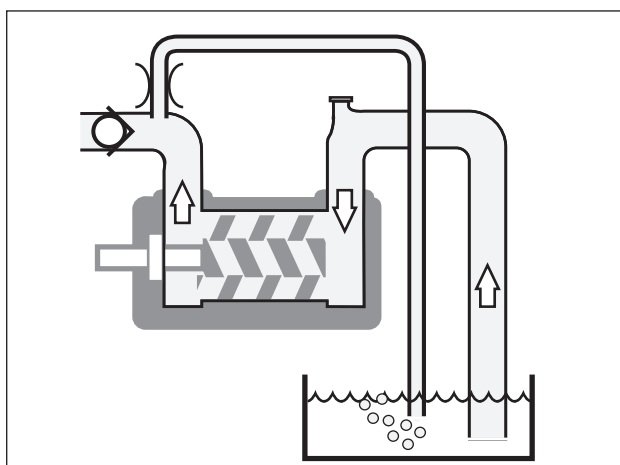

Fig. 8 Deaeration

## Strainer

The pump has to be protected from foreign matter, such as weld slag, pipe scale, etc., that could enter the pump via the suction line. If the cleanliness of the system cannot be guaranteed, a strainer must be installed in the inlet pipe near the pump. For practical reasons a suction strainer with 0.6 mm mesh openings is recommended:

The size of the strainer should be selected so that it is large enough to allow adequate pressure at the pump inlet. The pressure drop across the strainer should preferably not exceed 0.1 bar at max. flow rate and normal operating viscosity. A vacuum gauge between the strainer and the pump inlet is recommended to indicate when the strainer needs cleaning.

*Note: The service life of the pump is decisively influenced by the degree of contamination of the fluid being conveyed, that means, by the number, size and hardness of the abrasive components.*

## Shaft seal drain

The pump should be installed so that any leakage from the shaft seal does not become a hazard. As the shaft seal has to be lubricated a small amount of oil dripping cannot be avoided.

Provisions to collect the leakage from the shaft seal must be made.

A drain pipe can be connected to the drain connection on the pump, (not applicable to pump series LPD). However, when pumping heavy fuel oil or any other liquid that is likely to become very viscous at ambient temperature, we recommend that the liquid is allowed to drop freely from the drain opening.

## Liquid trap

In some mounting arrangements the pump may not retain the liquid at stand still. In such installations the suction pipe should be arranged so it forms a liquid trap together with the pump, keeping the pump half filled with liquid. See fig. 11.

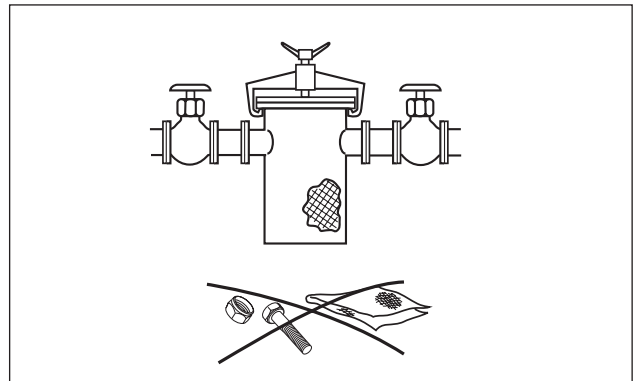

Fig. 9 Strainer

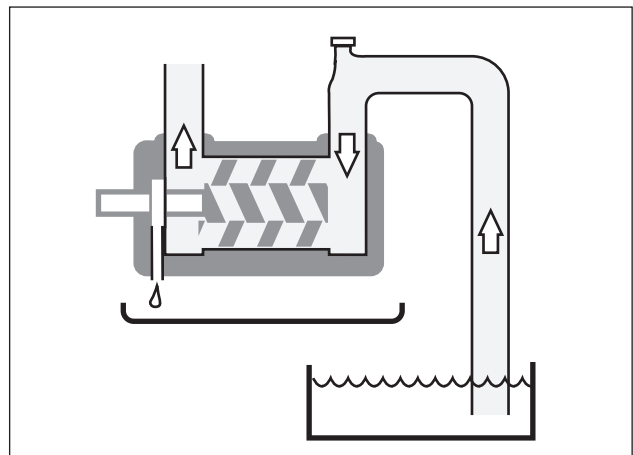

Fig. 10 Shaft seal drain

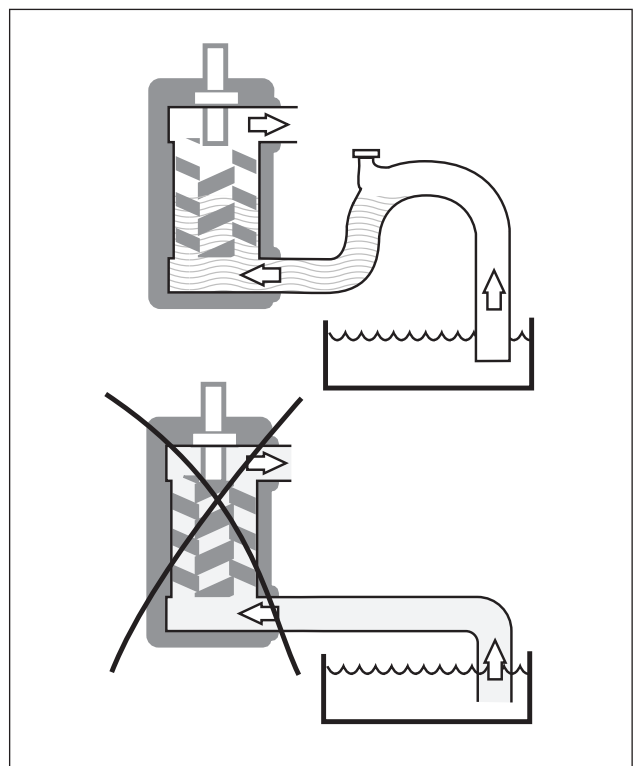

Fig. 11 Liquid trap

## Gauges

Gauges for monitoring the pump's working conditions are recommended. These gauges should be placed readable as close to the pump's in- and outlet flanges as possible. On standard pumps, series ACE, LPE, ACG/UCG, ACF/UCF and LPQ, there are gauge connections for both in- and outlet.

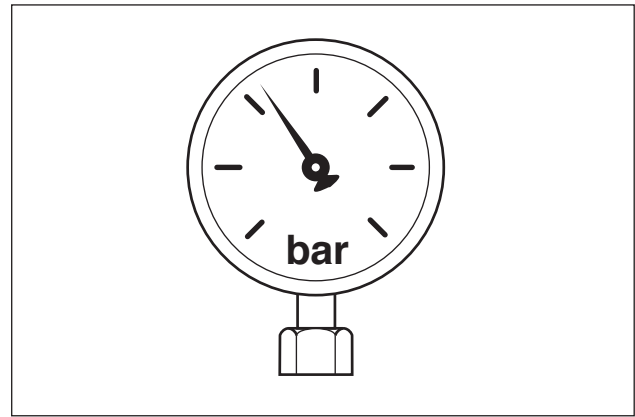

Fig. 12 Gauges

## Pressure relief valve

All systems with screw pumps must be equipped with a pressure relief valve installed immediately adjacent to the pump.

In the standard versions of IMO AB low pressure pumps, this pressure relief valve is an integral part of the pump to protect the system against excess pressure.

When liquid is circulated through the valve it heats up in proportion to the set pressure level and the percentage of by-passed liquid. 100% by-pass can only be tolerated for less than about 3 minutes, 50 % by-pass generally for unlimited periods of time.

If more than 50% recirculation is anticipated, a value specific to each application should be determined by closely monitoring the pump body temperature.

If the pump is operating in line with a separate pressure control valve (see fig. 13), the setting of the relief valve should be high enough so as not to interfere with the control valve. Likewise, if two pumps are operating in parallel, the setting should be such that interference between the two valves is avoided.

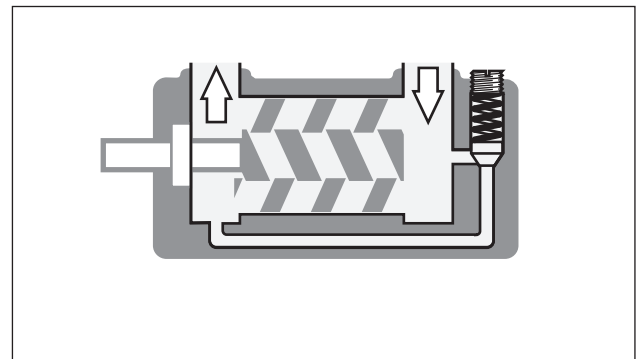

Fig. 13 Pressure relief valve

## Pressure testing and flushing

The system must be flushed and pressure tested before connecting the pump. If corrosive liquid, such as water is used, the system must be thoroughly drained, dried and protected against corrosion after having been flushed.



**Oil leakage may make the floor slippery and cause personal injury.**

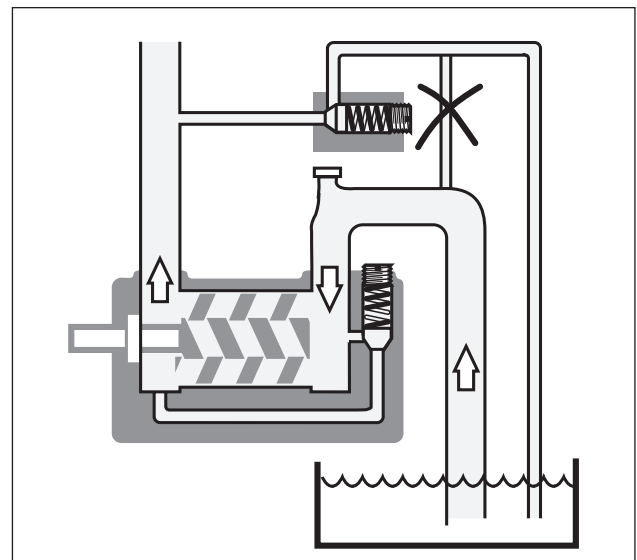

Fig. 14 External control with pressure relief valve

# Start-up

## Before starting

After installation and whenever it can be assumed that the pump has been emptied, the pump must be thoroughly filled with liquid. See fig 15.

For ACE Generation 3, LPE Generation 3, ACG Generation 7 and ACF Generation 4 delivered after 1997, ACF Generation 5 and LPQ the pumps have been fitted with deaeration plugs making venting of the shaft seal compartment easy before start-up.

In installations with positive suction pressure: After opening the inlet and outlet valves, simply open the deaeration plug a few turns until oil sips out. Tighten the plug.

In installation with negative suction pressure: After opening the inlet and outlet valves, remove the deaeration plug and fill the shaft seal compartment with oil. Fit and tighten the plug. See fig. 16.

Note: for LPQ the amount of oil is appr 50 liter.

**⚠ Make sure the prime mover is locked out and can not be started accidentally.**

Rotate the shaft by hand while filling the pump, to ensure that the rotor bores and the shaft seal cavity is filled. On the smaller pumps: (LPD, ACD, ACE, LPE, ACG/UCG), this is done by rotating the fan on the electric motor after removing the fan cover.

**⚠ Do not forget to fit the motor fan cover again before making start of motor possible.**

On the ACF/UCF, LPQ and ABQ pumps, the pump can be turned using the shaft coupling. If the suction pipe cannot be completely filled, it is important to ensure that the trapped air is evacuated without any pressure build up. (See fig. 8 Deaeration).

### ATTENTION

**Starting a dry pump is likely to cause damage, especially to the shaft seal.**

## Direction of rotation

When the pump is ready to be started, switch the motor briefly on and off and check that the drive motor rotates in the correct direction as indicated by the rotation arrow.

The arrow is placed on different spots depending on the pump series.

### ATTENTION

**Don't mix up with arrow for inlet and outlet!**

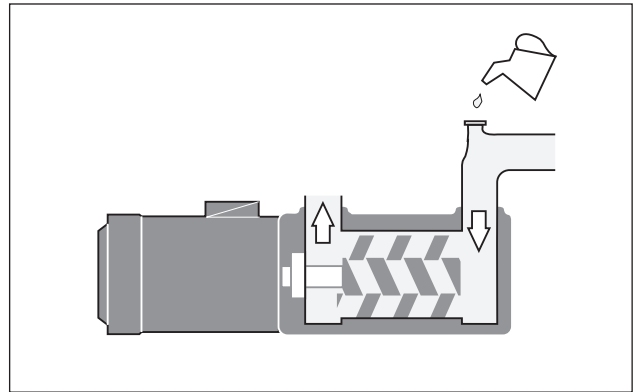

Fig. 15 Filling the pump

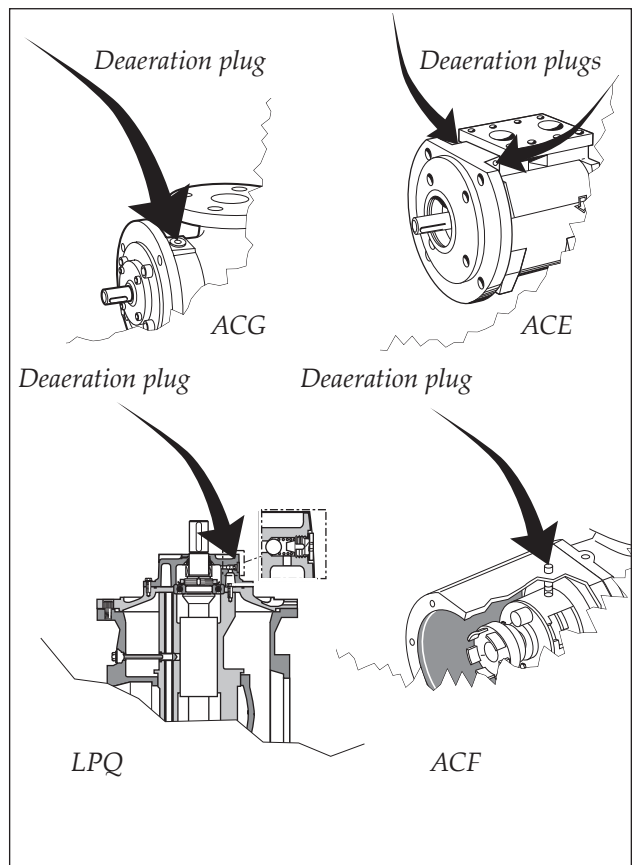

Fig. 16 Deaeration plugs

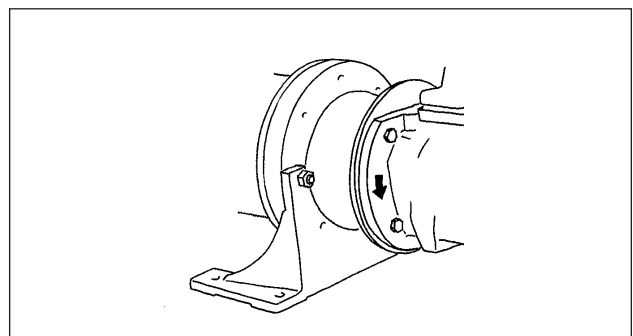

Fig. 17 Direction of rotation

## Starting

Check that all valves necessary for the operation are fully opened in both discharge and suction lines.

The first time, the pump should be started with the adjusting spindle of the pressure relief valve tightened to half of the available turns (the valve setting is increased when the spindle is turned clockwise).

By monitoring the pressure gauge it can be determined when the suction line is primed and the pump begins to work. Should the pump not operate normally soon after start, stop the pump within half a minute. Start again after about 3-5 minutes (the shaft seal must have time to cool off) and run for half a minute. This procedure may need to be repeated a couple of times if the suction line is extremely long. Should the pump still not work, it must be assumed there is a problem in the system that needs to be remedied. Check the suction line calculation on page 5 and/or see "Trouble shooting", page 10.

**⚠ Pumps with external ball bearing including grease nipple, must be regreased after one hour of running, while the pump is operating**

## Setting the pressure relief valve

The setting of the opening pressure is made as follows: Tighten the valve spindle by rotating clockwise to the maximum extent. The system pressure is regulated by throttling to required value. The pressure relief valve is eased until the pressure is just beginning to decrease by turning the spindle CCW. The valve is now preset for desired opening pressure. Open the throttling valve entirely.

**NOTE: The set screw on LPD is hidden behind a plate.**

## Adjusting the tuning

The tuning adjustment, which is a standard feature on ACF/UCF and LPQ (option on ACG/UCG and ABQ) pumps, is a device for minimizing the effects of dissolved and free air in lube oil systems. The tuning principle is described in the Product Description.

The tuning should be adjusted while the pump is working under normal operating conditions. This is done by turning the tuning spindle with an Allen key (size 8 mm for ACG/UCG, 12 mm for ACF/UCF and LPQ) to a position where the noise level comes to a minimum. On a double acting pump like the LPQ pump, there are two tuning valves, which must be adjusted individually.

Setting of tuning of the LPQ:

1. Before starting the setting check that both setting screws (8 mm socket head cap screw on the discharge side) are closed.
2. Turn the lower screw until the noise level obtains a minimum. (If turned too much the noise will increase again).

3. Turn the upper screw and continue to reduce the noise level. (If turned too much the noise will increase again).
4. Repeat item 2. and 3. in order to achieve the lowest possible noise level.

### Setting of tuning of the ACG/UCG and ACF/UCF:

1. Before starting the setting, check that the setting screw (8 mm: ACG/UCG, 12 mm: ACF/UCF, socket head cap screw on the discharge side) are closed.
2. Turn the screw CCW until the noise level becomes the lowest (if turned too much the noise will increase again).

Once set, the tuning needs no further adjustment, providing the operating conditions stay the same.

**NOTE: It's not possible to accidentally turn the tuning spindle too far.**

**⚠ If operating temperature exceeds 60°C (149°F), appropriate measures to avoid skin contact shall be provided.**

**⚠ Use hearing protections whenever high noise can be expected from pump, motor and/or environment.**

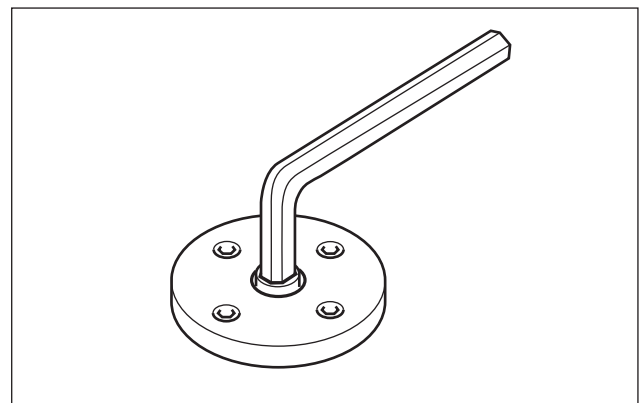



Fig. 18 Adjusting the tuning

# Trouble shooting

Problem	Cause	What to do
Wrong direction of rotation	<ul style="list-style-type: none"> <li>- Electric cables to motor wrongly connected.</li> </ul>	<p>Reverse the terminal connection on electric motor.</p> <div style="background-color: #e0e0e0; padding: 5px; border: 1px solid black;">  <p><b>Connecting and disconnecting of electric cables must be done only by personnel authorized to do such work.</b></p> </div>
The pump cannot be primed	<ul style="list-style-type: none"> <li>- Wrong direction of rotation.</li> <li>- Suction line is not open or pressure drop in the suction line is too high.</li> <li>- Major air leakage into the suction line.</li> <li>- The pump cannot evacuate the air through the discharge line due to excessive counter pressure.</li> </ul>	<p>See above.</p> <p>Check all components in suction line. The inlet condition should be checked with a vacuum gauge at the pump inlet.</p> <p>Check the suction line.</p> <p>See the chapter on Deaeration (see page 5).</p>
No flow	<ul style="list-style-type: none"> <li>- The pump is not primed.</li> <li>- The pressure relief valve is set below the counter pressure.</li> </ul>	<p>See above.</p> <p>Readjust the pressure relief valve to a value above counter pressure.</p>
Flow too low	<ul style="list-style-type: none"> <li>- The pressure relief valve is set too low (Discharge pressure also low).</li> <li>- Something is restricting the flow in the suction line. (This would usually cause noise).</li> <li>- The pumped liquid contains a significant amount of compressible gas, such as free air. (This would usually cause noise).</li> </ul>	<p>Readjust the pressure relief valve.</p> <p>Check all components in the suction line (strainers, valves etc.).</p> <p>See the chapter on Noise and Vibration. ( Page 11).</p>
Pressure too low	<ul style="list-style-type: none"> <li>- The pressure relief valve is set too low.</li> <li>- Counter pressure in the discharge line is too low due to a major leakage.</li> <li>- The valve piston is stuck in open position.</li> <li>- Something is restricting the flow in the suction line. (This would usually cause noise).</li> <li>- The pumped liquid contains a significant amount of compressible gas, such as free air. (This would usually cause noise).</li> <li>- A too small pump has been chosen.</li> </ul>	<p>Readjust the pressure relief valve.</p> <p>Check the components in the discharge line inclusive the recipients.</p> <p>Check the valve. See Maintenance and Service instruction for respective pump.</p> <p>Check all components in the suction line (strainers, valves etc.).</p> <p>See the chapter on Noise and Vibration. ( Page 11).</p> <p>Contact your IMO AB representative.</p>

Disturbance	Cause	What to do
<p><b>Pressure too high</b></p>	<ul style="list-style-type: none"> <li>- The pressure relief valve is set too high.</li> <li>- The oil is too cold (or has higher viscosity than anticipated).</li> <li>- Counter pressure in the discharge line is too high.</li> </ul>	<p>Readjust the pressure relief valve.</p> <p>Reduce the pressure setting until operational temperature has been reached.</p> <p>Check the discharge line.</p>
<p><b>Drive motor difficult to start or tends to stop by tripping the motor overload relay</b></p>	<ul style="list-style-type: none"> <li>- Counter pressure too high.</li> <li>- Liquid too cold</li> <li>- Motor is undersized for the prevailing conditions.</li> <li>- Electrical power supply faulty.</li> <li>- Motor overload relay set too low or is faulty.</li> <li>- Incorrect setting of Y/D starter.</li> </ul>	<p>See above: Pressure too high.</p> <p>Readjust the pressure relief valve to a lower value. Thus the power consumption for the pumping is relieved and overloading due to the high viscosity may be avoided. When the liquid has reached normal temperature and thus flows easily, the relief valve is reset to normal pressure.</p> <p>Check the motor.</p> <p>Check the motor and motor connection.</p> <p>Readjust or replace the relay.</p> <p>Readjust the setting of the starting sequence. The time before the motor overload relay is tripped should not exceed 10-15 seconds.</p>
<p><b>Noise and vibrations</b></p> <div style="border: 1px solid black; background-color: #e0e0e0; padding: 5px; margin-top: 10px;">  <p><b>Monitor the pump function and shut down if any sign of malfunction is noticed.</b></p> </div>	<ul style="list-style-type: none"> <li>- The flow to the pump is insufficient.</li> <li>- Insufficient support of pipe work.</li> <li>- Bad alignment</li> <li>- Air leakage into the suction line.</li> <li>- Free air in the liquid or gas cavitation.</li> <li>- Faulty electrical supply.</li> </ul>	<p>See chapter: The flow is too low.</p> <p>Check for pipe vibrations in the pump connections. Check that the pipes are sufficiently clamped.</p> <p>Check alignment, see page 4.</p> <p>Check the suction line for air leakage.</p> <p>For pumps with Tuning: Adjust the Tuning. If this does not help or for pumps without Tuning: Contact your IMO representative or IMO service dept.</p> <p>Check all three phases of the supply.</p>

