



A Member of the
COLFAX PUMP GROUP

Opti Line ACG8

Screw pump

Product description

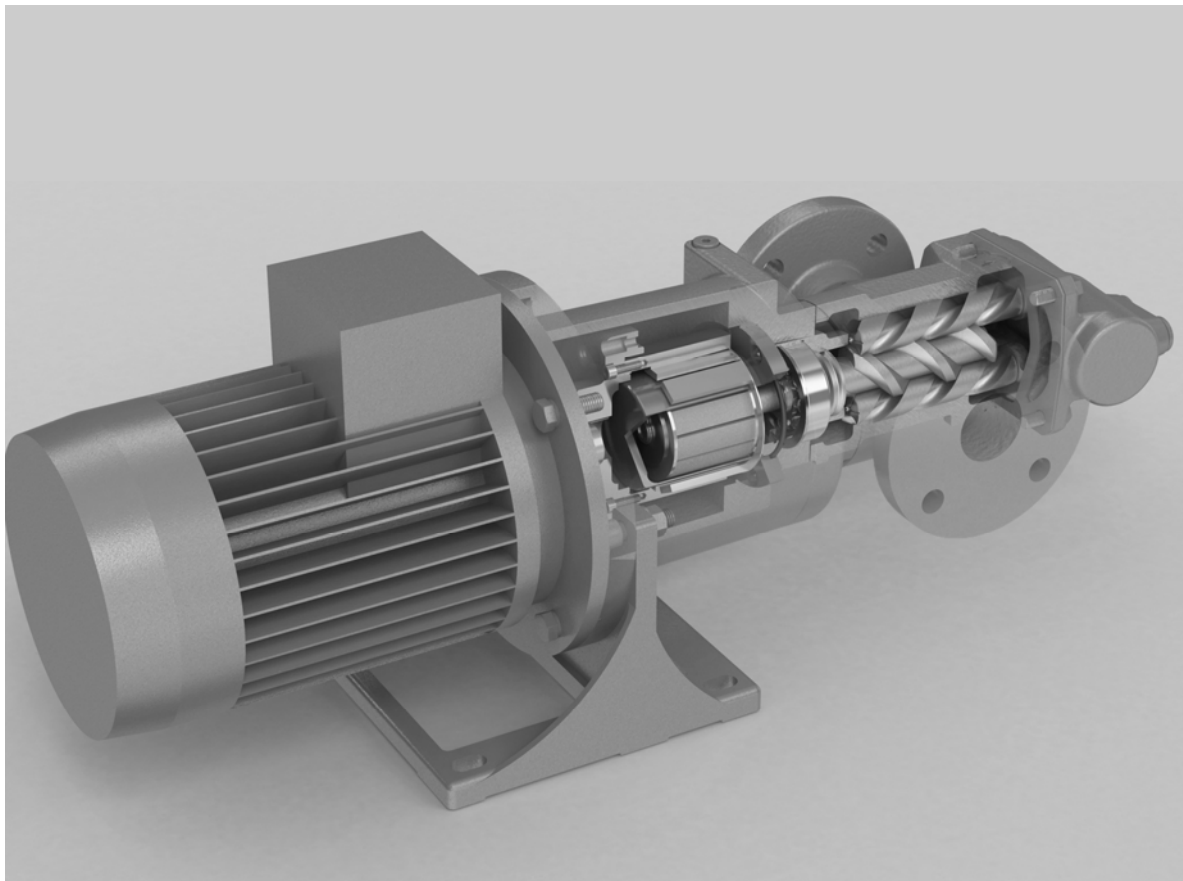

Flow volume: 80-1200 l/min

Max differential pressure: 16 bar

Applications: Lubrication, circulation and transfer

Application

The ACG pumps are used for a number of different fluids:

Lubrication oil, fuel oil, vegetable oil, hydraulic oil and other hydraulic fluids, glycol, polymers, emulsions, and any non-aggressive fluid with sufficient lubricating properties.

When so required the ACG pump may be certified according to any of following classification societies: DNV, BV, LRS, ABS, RS, GL, RINA, KR, NK or CCS.

Typical applications are:

- Lubrication of diesel engines, gears, gas and steam turbines, hydro turbines and paper machines.
- Circulation for cooling and filtration in large machineries, hydraulic systems and transformer oil for insulation in transformers.
- Transfer onboard ships, in oil factories, refineries, tank farms etc.
- Fuel supply duties for diesel engines.

Technical data

Discharge pressure

Maximum discharge pressure is 16 bar.

Differential pressure

Maximum differential pressure is 16 bar and minimum 1 bar

For low viscosity this value is reduced according to the table below. It may also be reduced at high speed/high viscosity related to the pump size and the torque capability of the selected magnetic shaft coupling. Please refer to your IMO representative or use the pump selection software WinPump to determine the exact operating limits.

Viscosity (cSt)	2	7	12	20	30	37
Max. diff. pressure (bar)	5	8	10	12	15	16

Inlet pressure

Maximum inlet pressure is 15 bar.

Minimum inlet pressure is -0,85 bar, however adjusted upwards related to pump size, operating speed, viscosity and vapor pressure. Please refer to your IMO representative or use the pump selection software WinPump to determine the exact operating limits.

Displacement

Size, lead	045K	045N	052K	052N	060K	060N	070K	070N	070D
Displacement cm ³ /r	65	82	103	126	159	193	251	307	359

Design

The OptiLine ACG pump is a positive displacement pump of 3-screw type. The design basically meets the requirements of EN ISO 14849.

Pressure relief valve

The pump is equipped with an integral pressure relief valve with internal return, limiting the differential pressure across the pump and protecting the pump, should the discharge line be blocked. The valve is adjustable for different opening pressures. The value of the pressure limit can be set at the factory and should be adjusted at installation (see Installation & Startup instruction for low-pressure pumps).

The maximum pressure accumulation varies with pump size, speed and viscosity, but will normally not exceed 4 bar.

The characteristic of the valve allows the valve to be used as pressure regulating valve when not too high demands on pressure modulation are required. The valve has a maximum set pressure of 16 bar.

Drive

The power from motor to the Opti Line ACG pump is transmitted without mechanical contact over a magnetic coupling. A coupling hub with a set of permanent magnets is mounted on the pump shaft. This hub is totally enclosed by a stainless steel can. The motor hub with another set of permanent magnets rotates on the outside of this can. Thus the pumped liquid is totally contained within the pump without the use of a conventional shaft seal.

The pump is designed for this type of drive only.

Speed

The maximum speed is 3600 rpm. For higher speeds contact your IMO representative.

Rotation

The ACG pump is designed to operate in one rotational direction only, as standard clockwise when facing the shaft end. For shorter periods of time, a few minutes for emptying a discharge line, the pump may be operated in reverse direction, provided the back pressure is limited to 3 bar.

Fluid viscosity

1.6 cSt up to 1500 cSt.

Fluid temperature

-20°C up to 180°C.

Sound level

Typical sound level refers to pump with standard driver and free field conditions at 5 bar, 2950 rpm and 40 cSt, measured according to ISO-3741.

PumpSize	045	052	060	070
Sound level dB(A)	59	63	66	68

Moment of inertia

Moment of inertia, 10⁻³ kgm²
Pump with complete coupling

Size	045	052	060	070
NHBP	15	16	-	-
NJBP	16	17	-	-
NKBP	17	17	28	67
NLBP	17	17	28	72
NMBP	19	19	34	78

Mounting attitude

The Opti Line ACG pump can be mounted in any attitude.

Material and design

Pump body	Nodular cast iron
Power rotor	Steel
Idler rotors	Perlitic cast iron
Elastomers	Viton

For handling of fluids that may be aggressive to above materials consult your IMO representative.

Viscosity table

cSt	2	4	8	20	37	75	200	400	800	1500
SSU	32.6	39.2	52.2	99.4	174	346	927	1850	3700	6940

Units

The following units are frequently used for specification of pumps:

	SI-unit	IMO units	USA units	conversion
Pressure	Pa (MPa)	bar	psi	1 bar = 14.5 psi = 0.1 MPa
Speed	r/s	rpm	rpm	1 rpm = 0.016667 r/s
Viscosity	mm ² /s	cSt	SSU	mm ² /s = cSt (see table)
Temperature	°C	°C	°F	°C = (°F-32)/1.8
Length	m	mm	inch	1 mm = 0.0394 inch
Flow rate	m ³ /s	lit/min	GPM	1 lit/min = 0.264 USGPM

Performance guide

Typical performance values at 5 bar						
Flow calculated at 26 cSt, power at 260 cSt						
For values under other operating conditions, please refer to the IMO AB pump selection software WinPump (download it from www.imo.se and apply for licence).						
045K				045N		
rpm	l/min	kW	form	l/min	kW	form
1470	77	1,5	NJBP	95	1,8	NJBP
1770	97	1,8	NJBP	119	2,2	NJBP
2950	174	3,5	NJBP	216	4,2	NJBP
3550	213	4,4	NJBP	265	5,4	NJBP
052K				052N		
rpm	l/min	kW	form	l/min	kW	form
1470	125	2,2	NJBP	153	2,7	NKBP
1770	156	2,8	NJBP	191	3,4	NKBP
2950	277	5,3	NKBP	340	6,4	NKBP
3550	339	6,9	NLBP	415	8,0	NKBP
060K				060N		
rpm	l/min	kW	form	l/min	kW	form
1470	197	3,7	NLBP	240	4,4	NLBP
1770	245	4,6	NLBP	298	5,5	NLBP
2950	432	8,9	NLBP	525	10,5	NLBP
3550	528	11,3	NLBP	641	13,3	NLBP
070K				070N		
rpm	l/min	kW	form	l/min	kW	form
1470	314	6,6	NKBP	388	7,8	NKBP
1770	389	8,5	NKBP	480	9,9	NKBP
2950	686	16,8	NKBP	843	21,0	NLBP
3550	836	21,8	NKBP	1 027	27,2	NLBP
070D						
rpm	l/min	kW	form			
1470	440	9,7	NLBP			
1770	548	12,4	NLBP			
2950	971,3	24,7	NLBP			
3550	1186,7	32,0	NLBP			

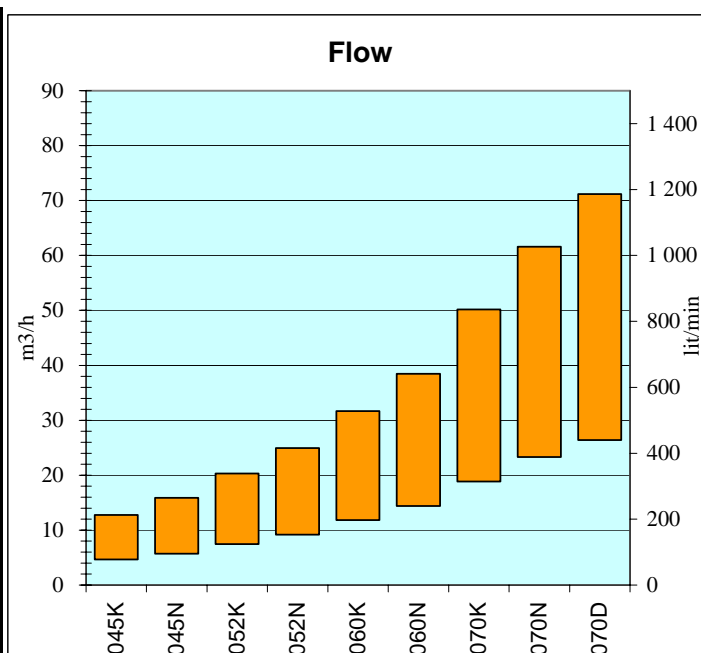

The performance shown above is calculated at a certain pressure and viscosity.

In order to achieve the right selection of pump, magnetic coupling and motor, the IMO AB pump selection program WinPump has to be used. The program can be down-loaded free from www.imo.se.

Pump model code

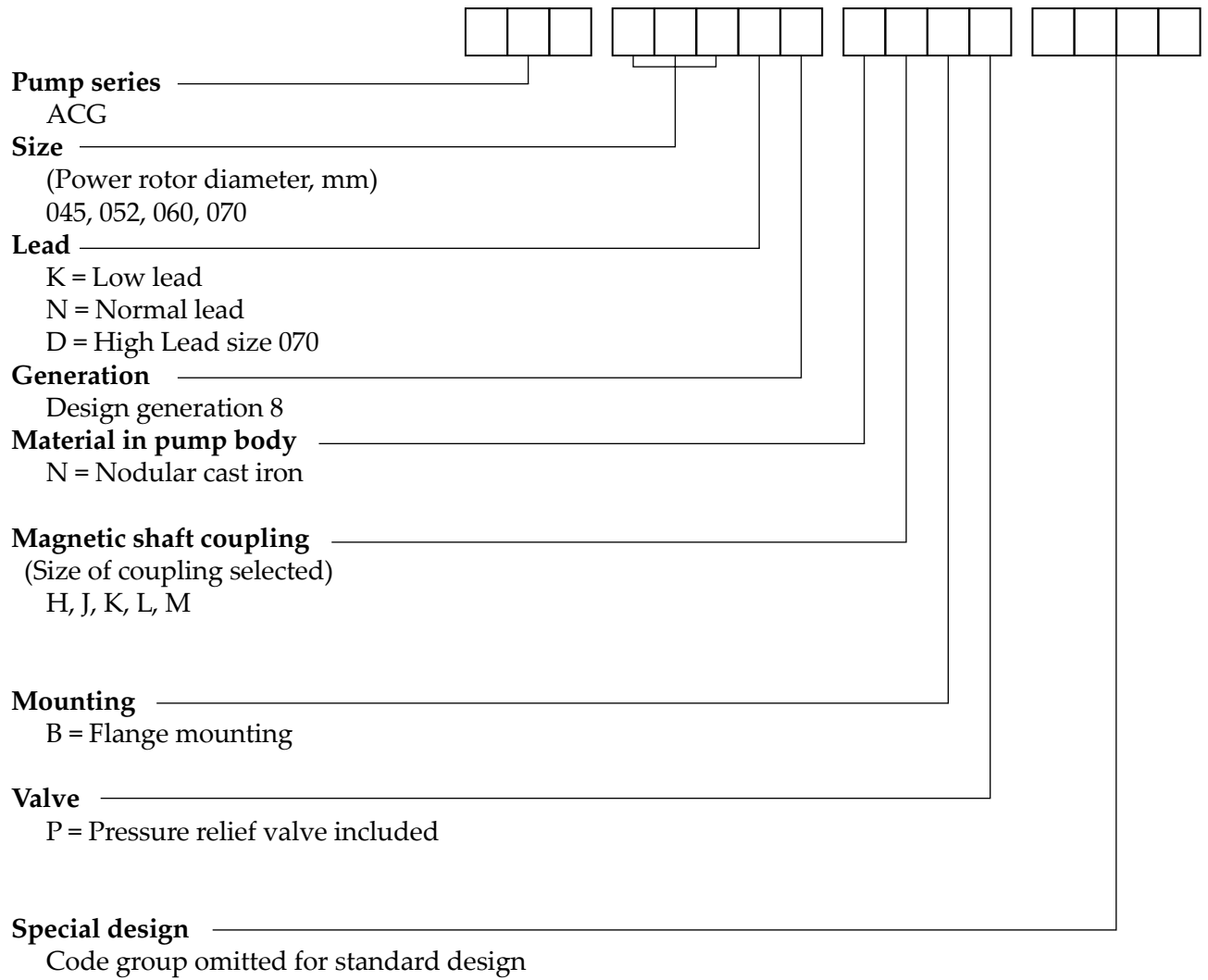

Pump dimensions

Pump size	IEC No	Frame size	A	AI	AC	B	C	D	D1	D2	F	G	G1	H	HD	J	K	L	M1	M					
045	100	F215	796	308	199	110	155	125	221	188	230	75	185	22	309	250	215	15	24	14					
	112		810	322	215										322										
	132	F265	880	371	255		185		226		270	95	225	23	373						300	265	18	24	14
	160	F300	1036	495	314				235		238	305	115	265	20						475	350	300	18	30
052	100	F215	805	308	199	122.5	155	126	222	196	230	75	185	22	309	250	215	15	24	14					
	112		819	322	215										322										
	132	F265	889	371	255		185		227		270	95	225	23	373						300	265	18	24	14
	160	F300	1045	495	314				235		239	305	115	265	20						475	350	300	18	30
060	132	F265	947	371	255	140	185	168	269	211.5	270	95	225	23	373	300	265	18	24	14					
	160	F300	1103	495	314																235	281	475		
	180		1165	557	358				495		350	300	18	30	18										
070	132	F265	986	371	255	150	185	181	296	224	270	95	225	23	373	300	265	18	24	14					
	160	F300	1156	495	314																235	322	475		
	180		1218	557	358				495		350	300	18	30	18										
	200	F350	1338	677	381		260		312		350	-	300	25	561						400	350	20	30	18
	225	F400	1465	775	448		295		331		385	-	335	25	640						450	400	20	30	18

Pump size	IEC No	Frame size	N	□	P	Q	QL	R	S	T	U	UL	V	Y	Z	*) Weight aprox. kg	CoG
045	100	F215	165	125	50	4x ∅18	20	165	125	50	4x ∅18	20	175	132	184	63	397
	112												196		205	68	392
	132	F265											228		237	84	401
	160	F300											228		237	127	441
052	100	F215	185	145	65	4x ∅18	20	185	145	65	4x ∅18	20	175	132	184	70	421
	112												196		205	75	415
	132	F265											228		237	91	425
	160	F300											228		237	135	466
060	132	F265	200	160	80	8x ∅18	20	200	160	80	8x ∅18	20	196	124	204	108	471
	160	F300											228		236	148	507
	180												228		236	182	509
070	132	F265	220	180	100	8x ∅18	22	220	180	100	8x ∅18	22	210	146	220	128	505
	160	F300											256		266	168	554
	180												256		266	202	554
	200	F350											256		266	339	544
	225	F400											285		295	461	593

Pump dimensions

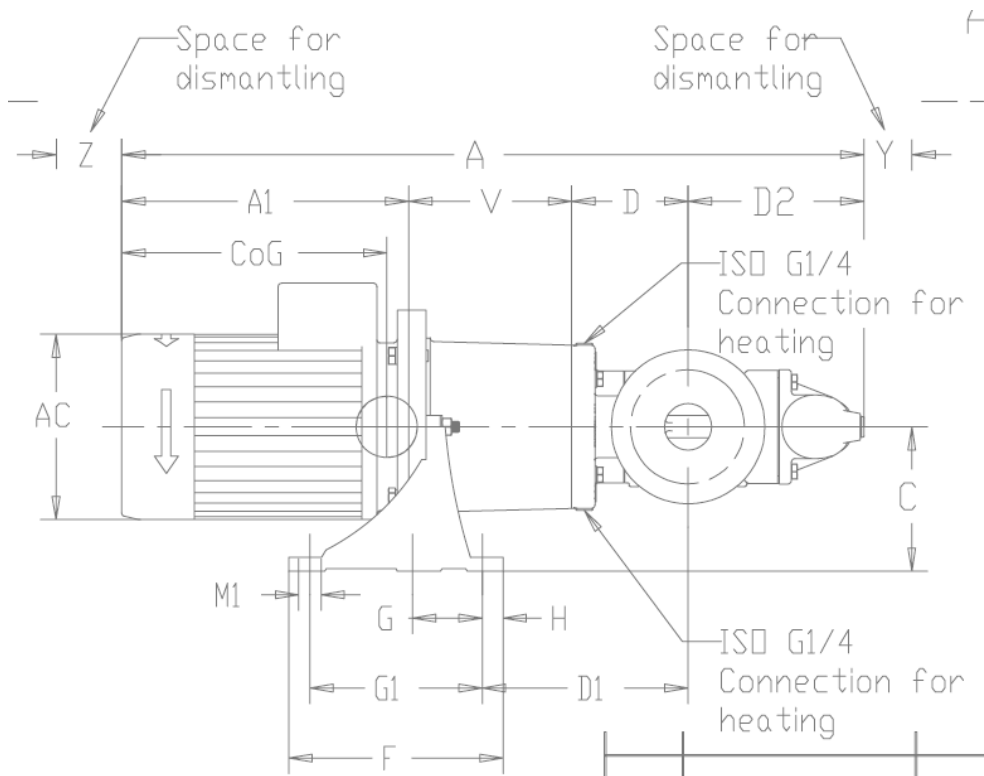
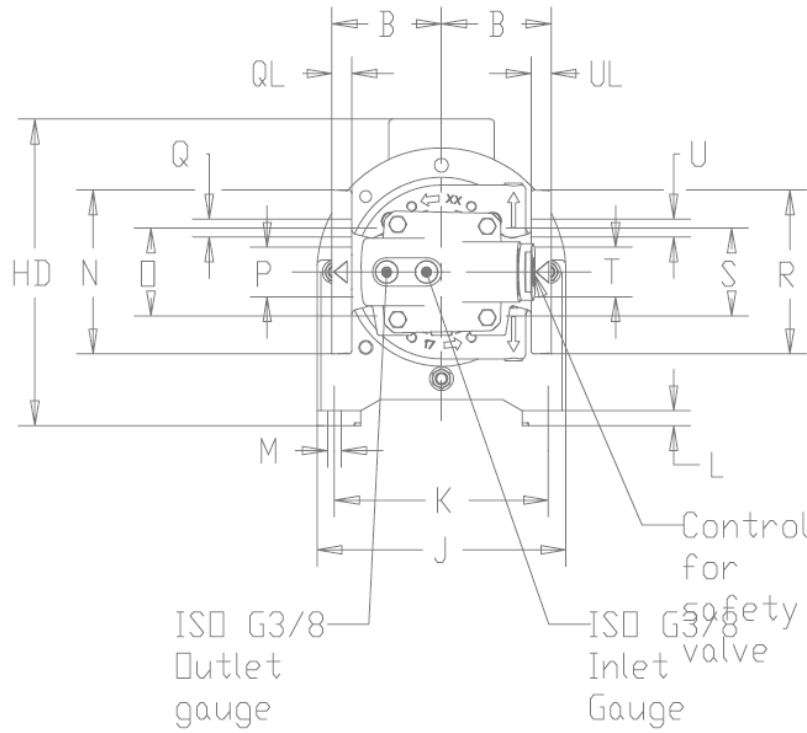

Sectional view

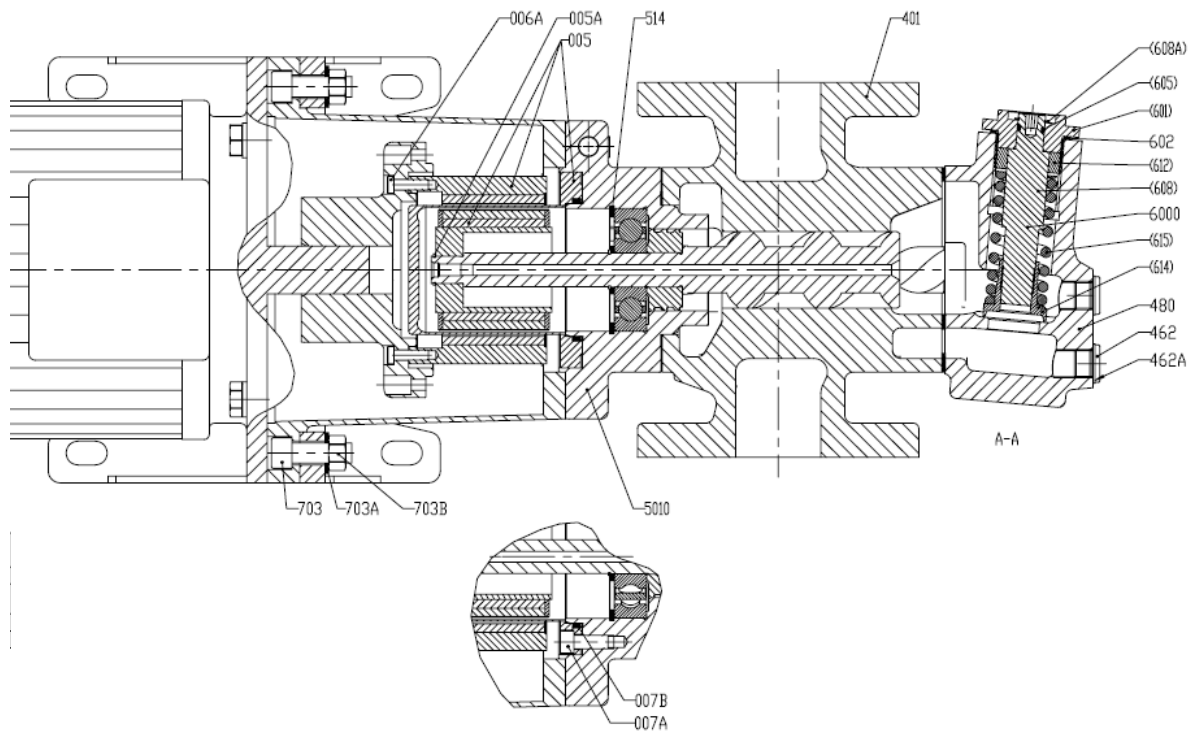
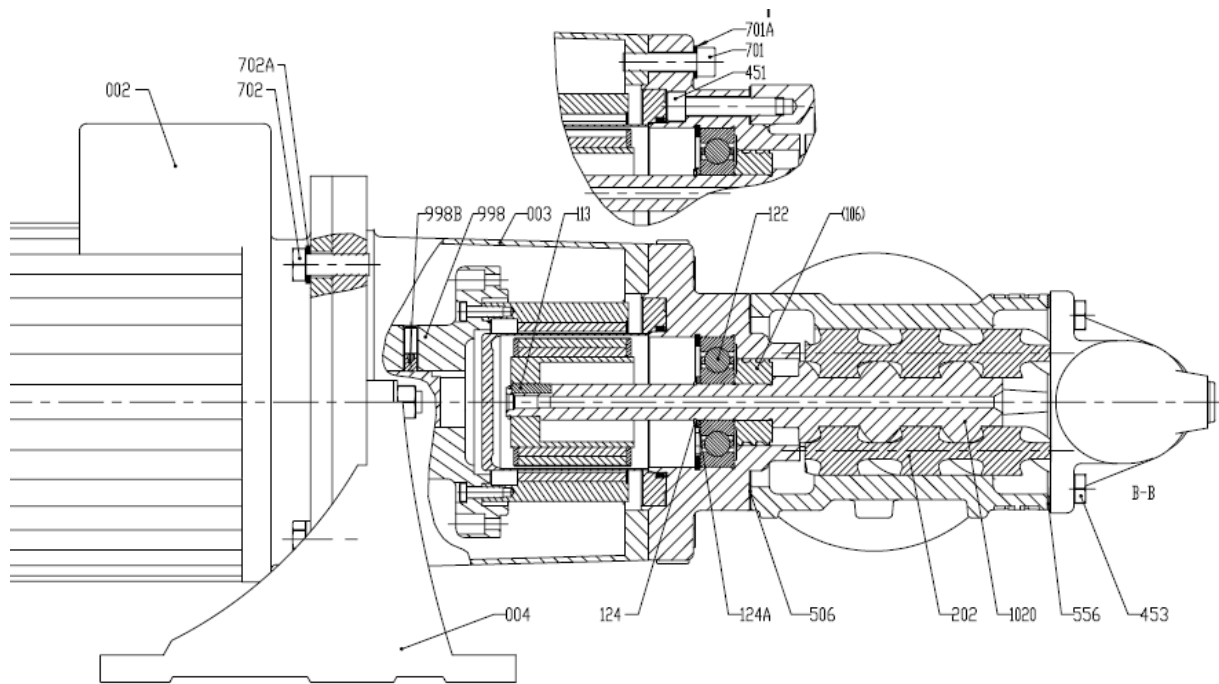

Sectional view

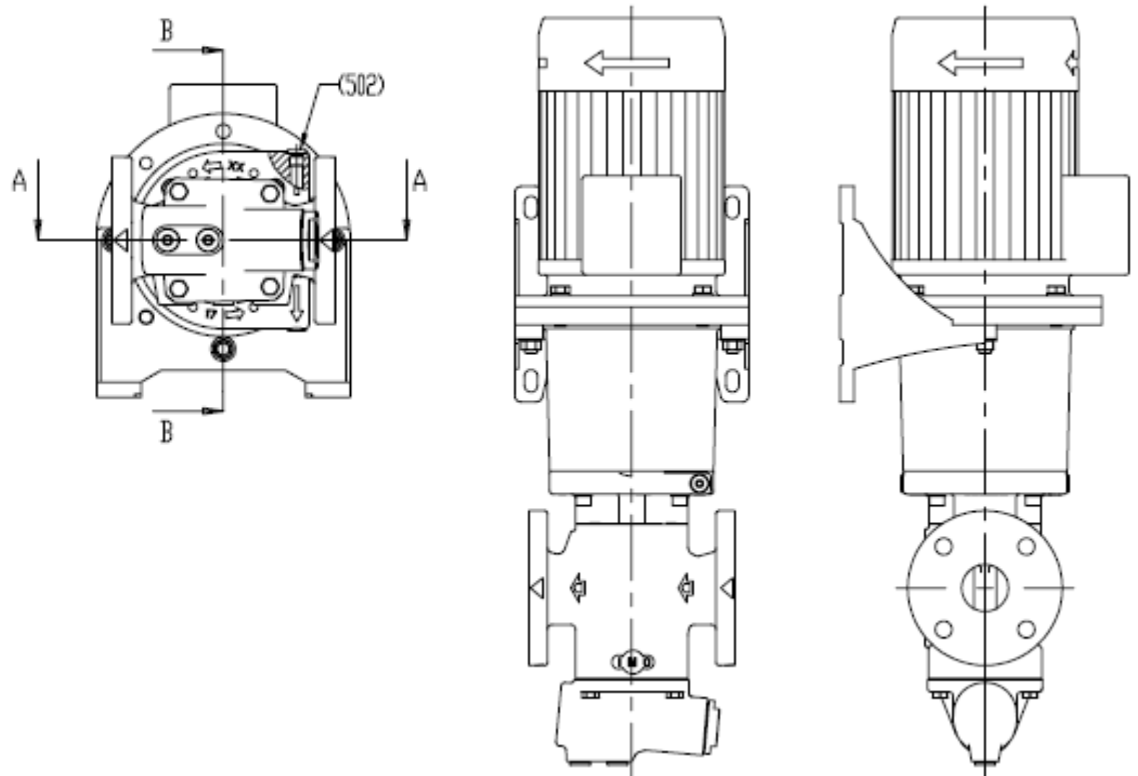

List of components

Pos No Denomination	Pos No Denomination	Pos No Denomination
002 Motor	453 Screw	(612) Regulating nut
003 Connecting frame	462 Plug	(614) Valve piston
004 Angle bracket	462A Washer	(615) Spring
005 Magnetic coupling	480 Valve housing	701 Screw
005A Retaining ring	5010 Compl. front	701A Washer
006A Screw	cover	702 Screw
007A Screw	(502) Plug 2 Steel	702A Washer
007B O-ring	506 Gasket	703 Screw
(106) Balancing	514 Retaining ring	703A Washer
113 Key	556 Gasket	703B Nut
122 Ball bearing	6000 Compl. Valve	998 Drive hub
124 Retaining ring	(601) Valve top cover	998B Screw
124A Support ring	602 Washer	Components with Pos No
202 Idler rotor	(605) O-ring	within parenthesis are
401 Pump body	(608) Valve spindle	part of subassembly
451 Screw	(608A) Retaining ring	

Installation

The OptiLine ACG pump is ange-mounted to an electric motor via a connecting frame and a magnetic coupling and has an angle bracket for mounting horizontally and vertically, see mounting instructio

Maintenance and Service

Spare parts for these pumps are easily available from stock. For detailed information and know-how about service, see the Installation & Service instruction for ACG-pumps or contact your IMO representative.



A Member of the
COLFAX PUMP GROUP

www.imo.se

IMO AB:

P. O. Box 42090, SE 126 14 Stockholm, Sweden
Telephone: +46 8 50 622 800, Telefax: +46 8 645 1509