



A Member of the
COLFAX PUMP GROUP

Std Line ACG7

Screw pump series

Product description

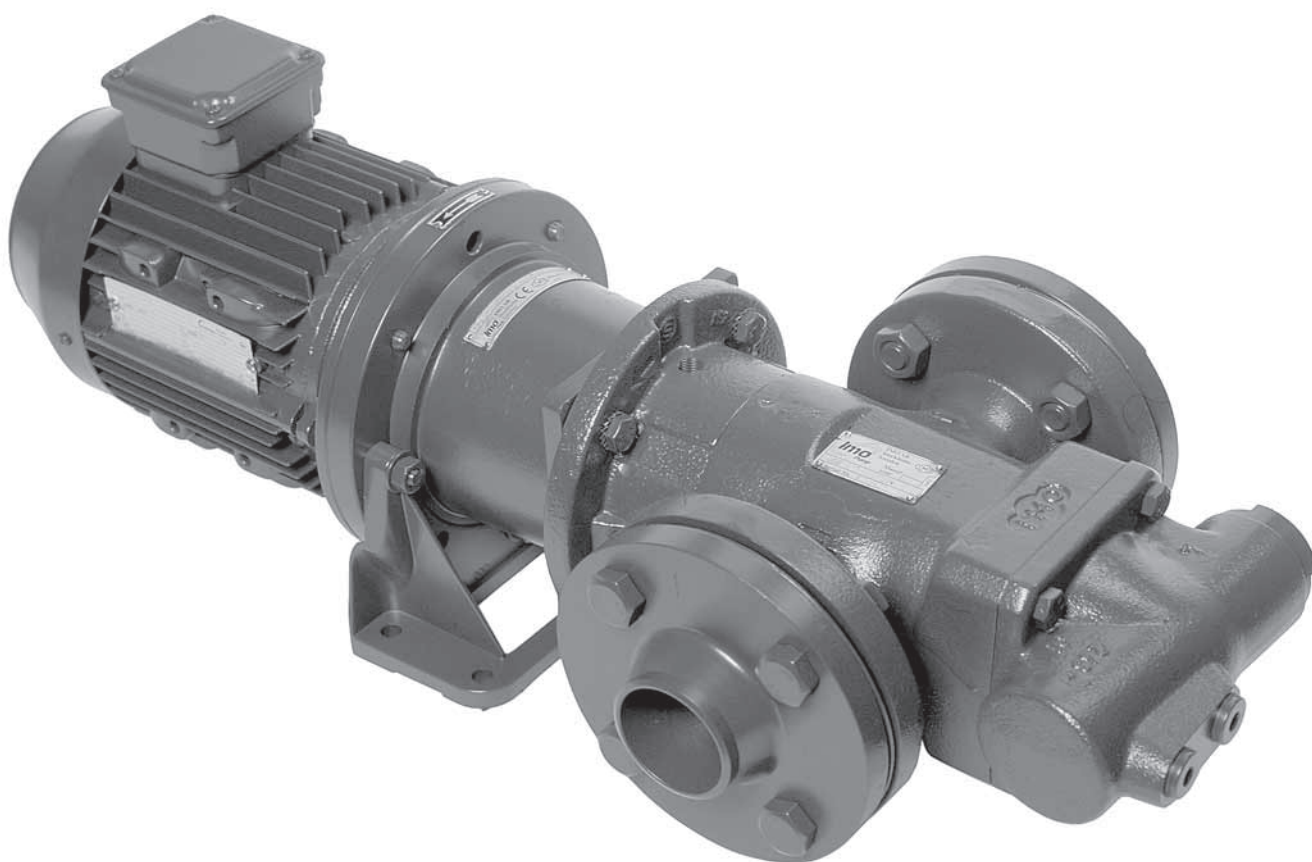

Flow volume: 65–850 l/min
Max differential pressure: 16 bar
Applications: Circulation, lubrication and transport

Applications

The Std Line (standard) ACG pumps come in two executions; Lube Line and Fuel Line. The main difference is the shaft seal design, optimized for light duty and heavy duty respectively. The ACG pump is used for a number of different fluids:

Lubrication oil, fuel oil, vegetable oil, hydraulic oil and other hydraulic fluids, glycols, polymers, emulsions and any non-aggressive fluid with some lubricating properties.

Typical applications are:

- Lubrication of diesel engines, gears, gas and steam turbines, hydro turbines, paper machines.
- Circulation for cooling and filtration in large machinery and hydraulic system.
- Supply and circulation in fuel oil systems.
- Transfer of oil onboard ships, in power plants, oil factories, refineries, tank farms etc.

Technical data

Discharge pressure

Maximum discharge pressure is 16 bar.

Differential pressure

Maximum differential pressure is 16 bar but is reduced at low viscosities as shown in this table.

Viskositet (cSt)	2	7	12	20	30	37	> 37
Max. differential pressure (bar)	5	8	10	12	15	16	16

Inlet pressure

Max. inlet pressure is 12 bar. Min. inlet pressure (suction capability) is dependent on fluid viscosity and rotation speed. It increases with decreasing viscosity and decreasing speed. Information about min. inlet pressure for each individual duty case can be obtained from IMO AB. (See also WinPump, page 4.)

Displacement

Size and lead	045K	045N	052K	052N	060K	060N	070K	070N
Displacement (cm ³ /r)	65	82	103	126	159	193	251	307

Pressure relief valve

The pump is equipped with an integral pressure relief valve with internal return, limiting the differential pressure across the pump and protecting the pump, should the discharge line be blocked. The valve is adjustable for different opening pressures. The value of the pressure limit can be set at the factory and should be adjusted at installation (see Installation & Service instruction for ACG pumps). The valve has a pressure accumulation of approximately 4 bar.

Drive

The ACG -pump is designed primarily for direct drive through a flexible shaft coupling. Under certain conditions other types of drive can be permitted, e.g. gear or pulley drives,

which create radial loads onto the shaft end. Permissible radial force varies with pressure, speed and inlet conditions.

Values for 8 bar, 1750 rpm and atmospheric inlet are as follows:

Size	045	052	060	070
Max. force (N)	900	1000	1000	1200

For higher pressure or higher radial load requirements, please contact IMO AB.

Speed

The maximum speed is 3600 rpm.

Max. operating speed may be reduced depending on inlet conditions. Please consult the Performance guide to find a corresponding speed limit in order to avoid cavitation problems.

Rotation

The ACG pump is designed to operate in one rotational direction only, as standard clockwise when facing the shaft end. Pumps for CCW operation can be delivered on special request. For shorter periods of time, a few minutes for emptying a discharge line, the pump may be operated in reverse direction, provided the back pressure is limited to 3 bar.

Fluid viscosity

Min. viscosity, all oil types 1.6 cSt

Lube Line (*Seal version code V*):

Max. viscosity, lube & hydraulic oils 800 cSt

Max. viscosity, fuel oils 200 cSt

Fuel Line (*Seal version code T*):

Max. viscosity 3 500 cSt

For higher viscosity contact IMO AB.

Fluid temperature

Lube Line -20°C to 90°C

Fuel Line -20°C to 155°C

Sound level

Typical pump sound levels referred to free field conditions at a distance of 1 m from the pump.

Noise of driver excluded in the quoted figures.

The sound levels are measured at a discharge pressure of 5 bar, speed 2900 rpm, viscosity 37 cSt.

Size	045	052	060	070
------	-----	-----	-----	-----

dB (A)	59	63	66	68
--------	----	----	----	----

Moment of inertia

For bare shaft pump

Size	045	052	060	070
------	-----	-----	-----	-----

10 ⁻⁶ kgm ²	0.3	0.7	1.4	3.0
-----------------------------------	-----	-----	-----	-----

Material and design

	Lube Line	Fuel Line
Pump body	Nodular cast iron	Nodular cast iron
Power rotor	Surface-treated steel	Surface-treated steel
Idler rotors	Surface-treated cast iron	Surface-treated cast iron
Shaft seal	Carbon/Silicon Carbide Viton elastomers	Silicon Carbide/Silicon Carbide Viton elastomers Spec.

For handling of fluids which may be aggressive to above materials please consult your IMO-representative.

Viscosity table

cSt	2	4	8	20	37	75	200	400	800	1500
SSU	33	39	52	99	174	346	927	1850	3700	6940

Units

The following units are frequently used for specification of pumps:

	SI	IMO	USA	Conversion
Pressure	Pa (MPa)	bar	psi	1 bar = 14.5 psi = 0.1 MPa
Speed	r/s	rpm	rpm	1 rpm = 0.016667 r/s
Viscosity	mm ² /s	cSt	SSU	mm ² /s = cSt (see table)
Temperature	°C	°C	°F	°C = (°F-32)/1.8
Length	m	mm	inch	1 mm = 0.0394 inch
Flow rate	m ³ /s	lit/min	GPM	1 lit/min = 0.264 GPM

Performance Guide

Typical performance values at 5 bar

Flow calculated at 26 cSt, power at 500 cSt

For values under other operating conditions, please refer to the IMO AB pump selection software WinPump (download it from www.imo.se and apply for licence).

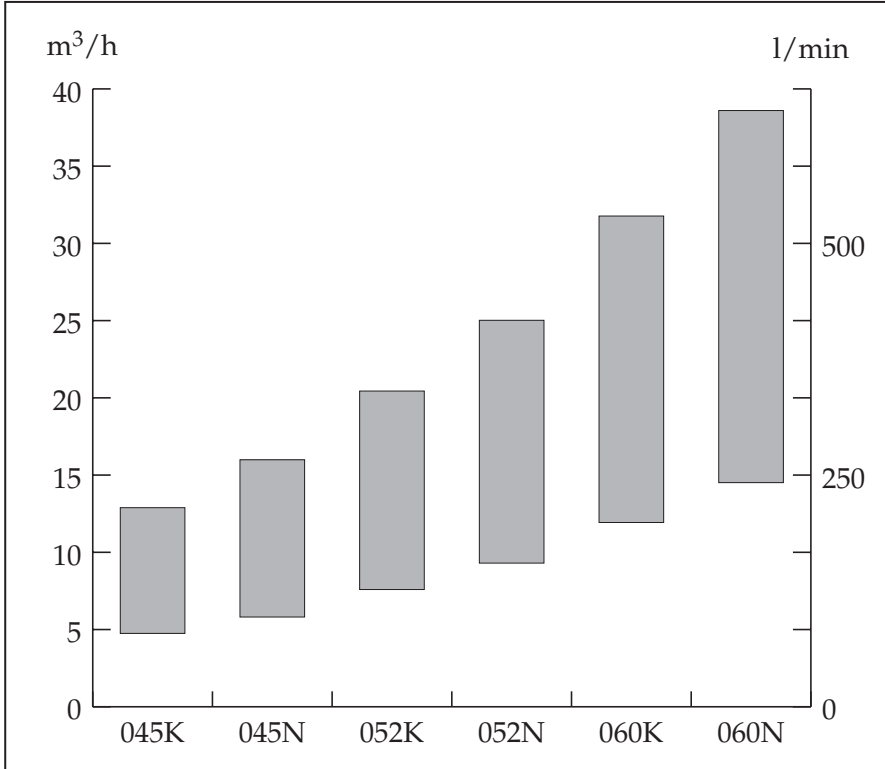

rpm	045K		045N	
	l/min	kW	l/min	kW
1470	79	1.6	97	2.0
1770	99	2.0	121	2.5
2950	176	3.8	218	4.7
3550	215	4.8	267	6.0

rpm	052K		052N	
	l/min	kW	l/min	kW
1470	126	2.5	155	3.0
1770	157	3.1	193	3.8
2950	279	5.9	341	7.3
3550	341	7.6	417	9.2

rpm	060K		060N	
	l/min	kW	l/min	kW
1470	199	3.8	242	4.6
1770	246	4.8	300	5.8
2950	434	9.2	528	11.1
3550	529	11.7	643	14.2

rpm	070K		070N	
	l/min	kW	l/min	kW
1470	321	3.8	395	4.6
1770	396	4.8	487	5.8
2950	692	9.2	849	11.1
3550	843	11.7	1033	14.2

Pump model code

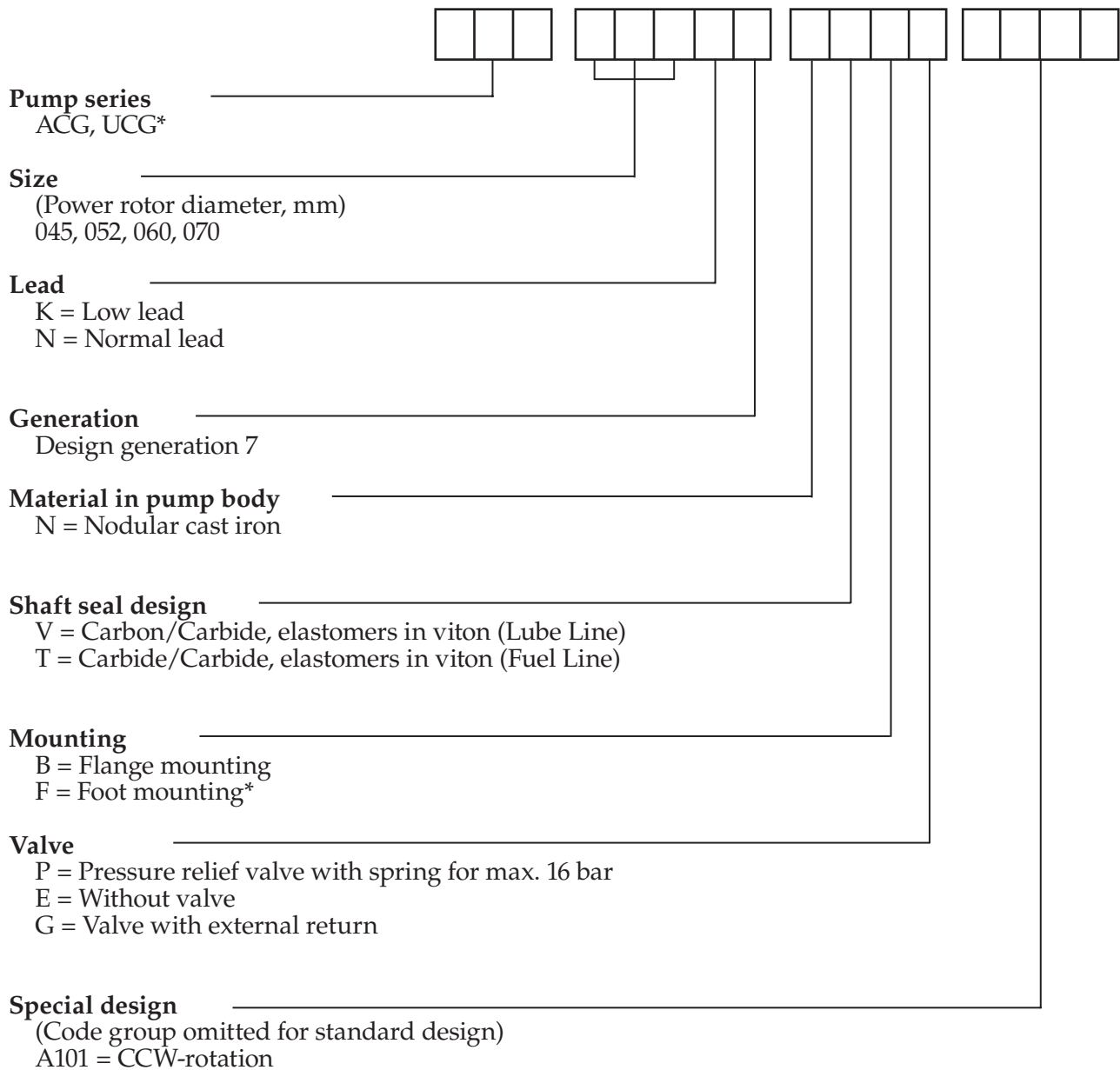

* For UCG and foot-mounted models, please contact IMO AB.

Pump dimensions

ump ACG (Valve design P, G, E)
Dimensions in mm

For UCG models, with ANSI-flanges and for foot mounted models, please refer to IMO AB.

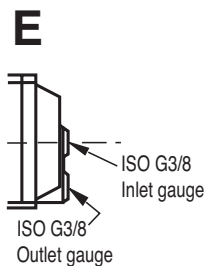
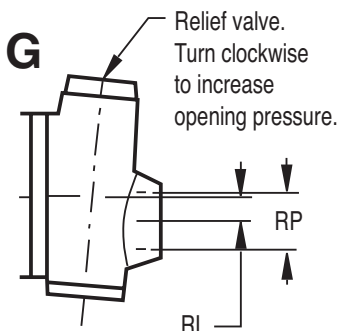
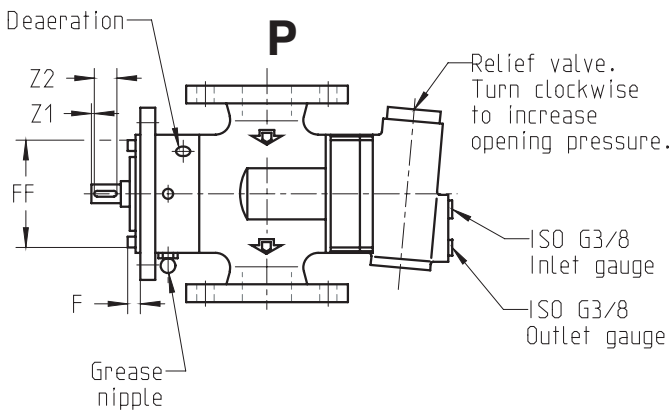
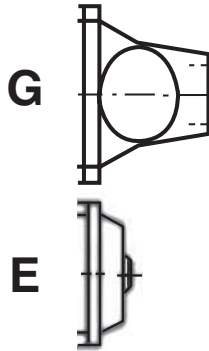
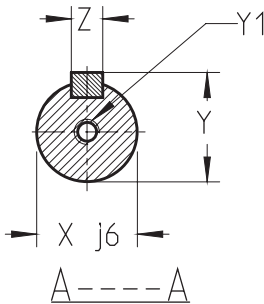
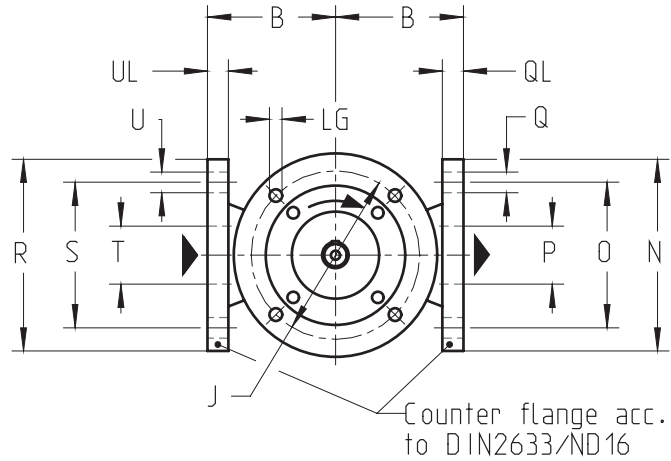
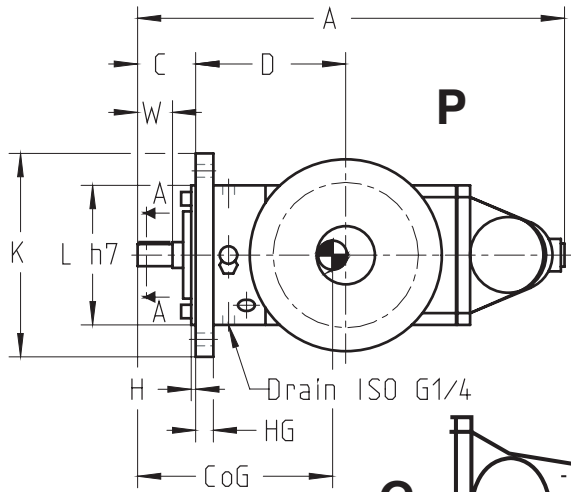

Pump size		045	052	060	070		
Main Dim.	A	367	396	460	490	xxxP	
	A	378	411	474	508	xxxG	
	A	319	350	397	427	xxxE	
	B	110	122,5	140	150		
	C	50	60	70	70		
	D	129	140	178,5	196		
	F	16	18	18	13		
	FF	113	127	153	173		
	CoG	185	200	285	300	xxxP,G	
	CoG	175	190	275	290	xxxE	
Flange dim.	H	4	4	4	4		
	HG	15	15	20	20		
	J	145	165	215	215		
	K	175	200	250	250	Tol. ISO h7	
	L	120	130	180	180		
Outlet	LG	11	15	18	18		
	N	165	185	200	220	Q-ty x diam	
	O	125	145	160	180		
	P	50	65	80	100		
	Q	4xØ18	4xØ18	8xØ18	8xØ18		
QL	20	20	20	22			
Inlet	R	165	185	200	220	Q-ty x diam	
	S	125	145	160	180		
	T	50	65	80	100		
	U	4xØ18	4xØ18	8xØ18	8xØ18		
	UL	20	20	20	22		
Return	RL	18	18	26	30	xxxG	
	RP	G-1 1/4	G-1 1/4	G-1 1/2	G-1 1/2	xxxG	
Drain Shaft	W	30	35	45	45	Tol. ISO j6	
	X	19	24	28	28		
	Y	21,5	27	31	31		
	Y1	M8x16	M8x16	M8x16	M8x16		Y1 x depth
	Z	6	8	8	8		
	Z1	3	3	3	3		
	Z2	22	28	36	36		
Weight (kg)		25	33	47	61	xxxP, G	
Weight (kg)		22	30	43	57	xxxE	

Fig. 1

Pump dimensions

Pump unit ACG (Valve design P, G, E)

Dimensions in mm

(With standard electric motor)

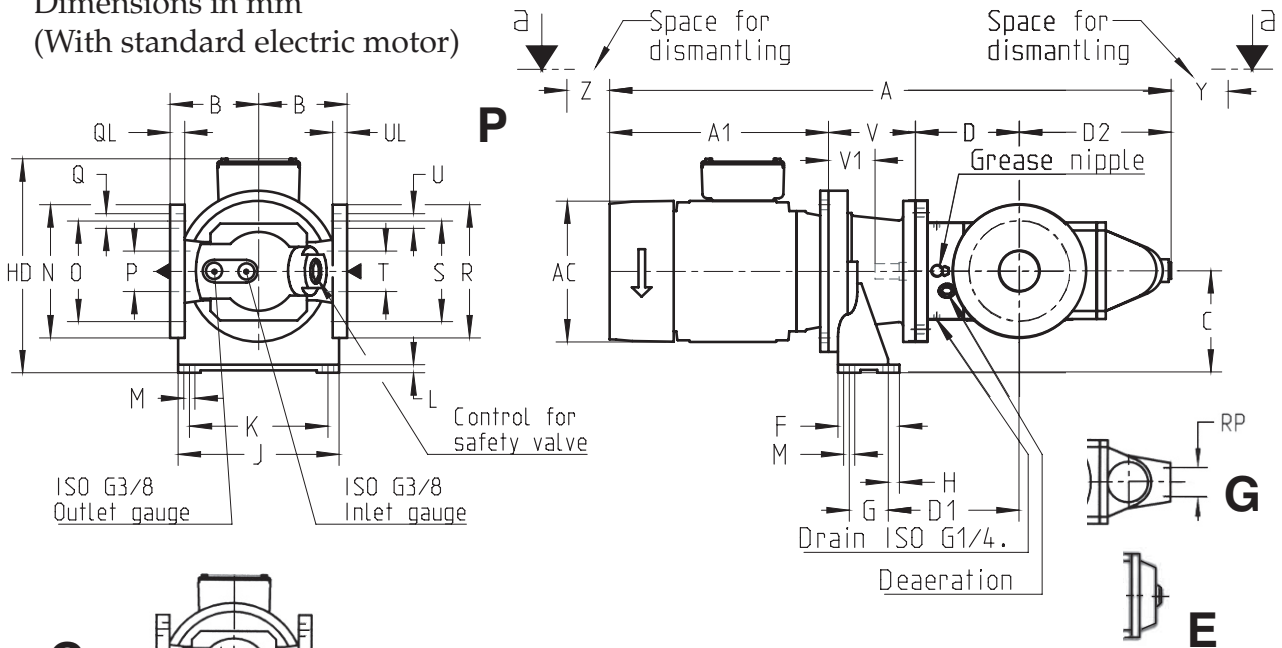

Pump size	IEC No	Frame	xxx P		xxxG		xxxE		C	F	G	H	HD	J	K	L	M	
			A1	AC	A1	AC	A1	AC										
045	80	F165	238	158	238	158	238	158	112	90	60	15	244	210	180	12	11	
	90		272	178	272	178	272	178				252						
	100	F215	308	199	308	199	308	199	132	110		29	286	250	220	15	14	
	112		321	215	321	215	321	215				299						
132	F265	371	255	371	255	371	255	160	116	80	16	348	290	260	18			
052	80	F165	238	158	238	158	238	158	112	90	60	15	244	210	180	12	11	
	90		272	178	272	178	272	178				252						
	100	F215	308	199	308	199	308	199	132	110		29	286	250	220	15	14	
	112		321	215	321	215	321	215				299						
	132	F265	371	255	371	255	371	255	160	116	80	16	348	290	260	18		
	160	F300	495	314	495	314	495	314	180	150	110	20	420	340	300	22	18	
060	100	F215	308	199	308	199	308	199	132	110	60	29	286	250	220	15	14	
	112		321	215	321	215	321	215				299						
	132	F265	371	255	371	255	371	255	160	116		80	16	348	290	260	18	
	160	F300	495	314	495	314	495	314	180	150		20	420	340	300	22	18	
	180		557	358	557	358	557	358			440							
070	100	F215	308	199	308	199	308	199	132	110	60	29	286	250	220	15	14	
	112		321	215	321	215	321	215				299						
	132	F265	371	255	371	255	371	255	160	116		80	16	348	290	260	18	
	160	F300	495	314	495	314	495	314	180	150		20	420	340	300	22	18	
	180		557	358	557	358	557	358			440							

Pump size	IEC No	Frame	xxx P A	xxxG A	xxxE A	B	D	D1	xxxP D2	xxxG D2	xxxE D2	N	O	P	Q	QL	R	S	T	U	UL	xxxG RL	xxxG RP	V	V1	Y	Z	*)Weight ca.kg
045	80	F165	679	690	631	110	129	173	188	199	140	165	125	50	Ø18	20	165	125	50	Ø18	20	18	G-1 1/4	124	74	75	75	27
	90		713	724	665			18														G-1 1/4						
	100	F215	760	771	712			18														G-1 1/4	135	85	75	85	28	
	112		773	784	725			18														G-1 1/4						
132	F265	843	854	795	18	G-1 1/4	155	105	80	105	30																	
052	80	F165	698	713	652	122,5	140	184	196	211	150	185	145	65	Ø18	20	185	145	65	Ø18	20	18	G-1 1/4	124	64	85	65	41
	90		732	747	686			18														G-1 1/4						
	100	F215	779	794	733			18														G-1 1/4	135	75	85	80	36	
	112		792	807	746			18														G-1 1/4						
	132	F265	875	890	829			18														G-1 1/4	168	108	90	110	38	
	160	F300	1035	1050	989			18														G-1 1/4	204	144	100	140	40	
060	100	F215	846	860	783	140	178,5	227,5	211,5	225,5	148,5	200	160	80	Ø18	20	200	160	80	Ø18	20	26	G-1 1/2	148	78	95	85	55
	112		859	873	796			26														G-1 1/2						
	132	F265	957	971	894			26														G-1 1/2	196	126	95	130	59	
	160	F300	1089	1103	1026			26														G-1 1/2	204	134	100	140	54	
	180		1175	1189	1112			26														G-1 1/2	228	158	105	160	59	
070	100	F215	876	894	813	150	196	245	224	242	161	220	180	100	Ø18	22	220	180	100	Ø18	22	30	G-1 1/2	148	78	95	85	69
	112		889	907	826			30														G-1 1/2						
	132	F265	987	1005	924			30														G-1 1/2	196	126	95	130	73	
	160	F300	1119	1137	1056			30														G-1 1/2	204	134	100	140	68	
	180		1205	1223	1142			30														G-1 1/2	228	158	105	160	73	

Fig. 2

Sectional view

ACG/UCG

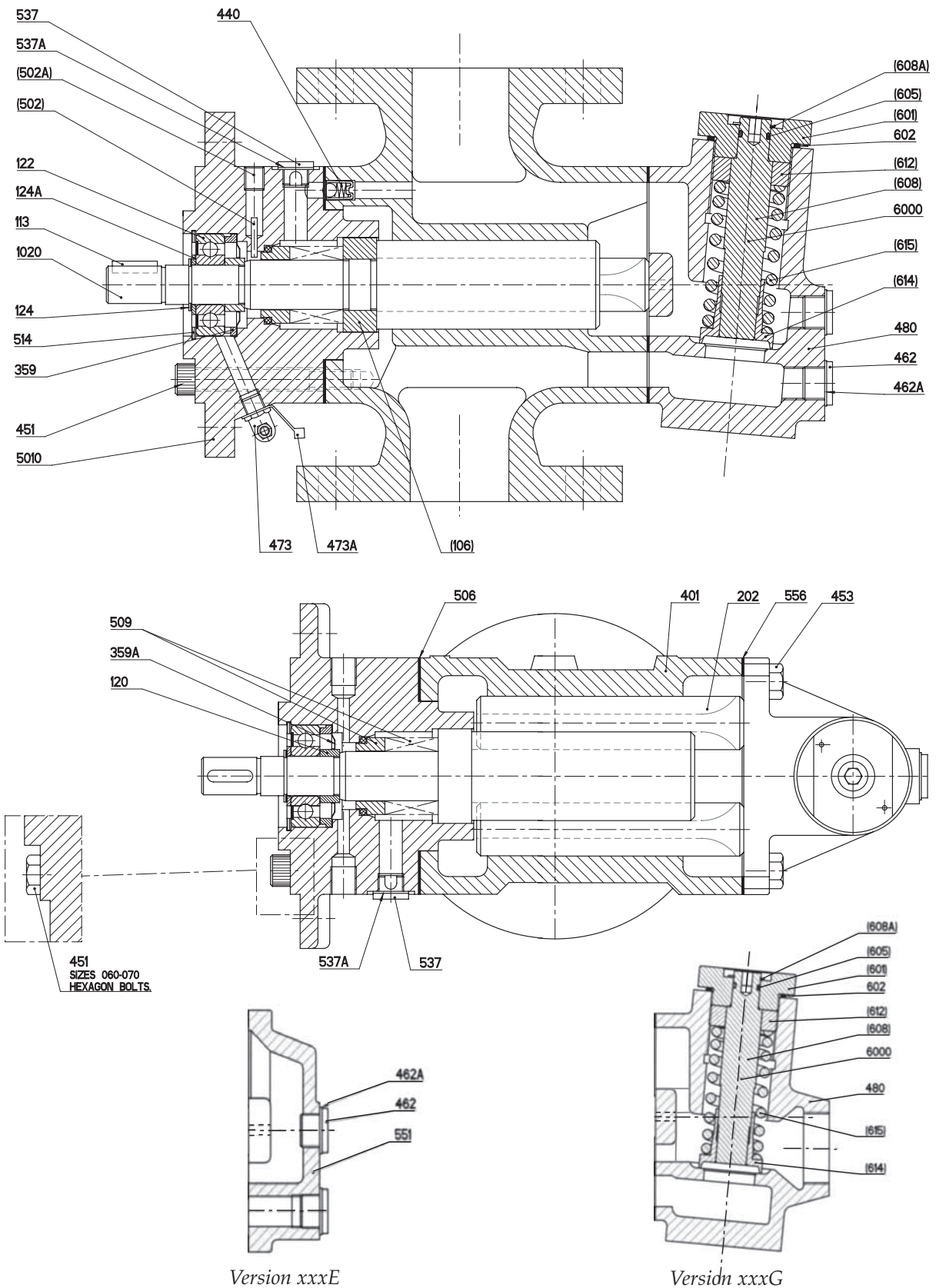

Fig. 3

List of components

Pos Nr	Denomination	Pos Nr	Denomination	Pos Nr	Denomination
1020	Power rotor	437	O-ring	514	Retaining ring
106	Balancing piston	440	Return valve	537	Plug
113	Shaft key	451	Screw	537A	Sealing washer
120	Distance sleeve	453	Screw	551	Rear cover
122	Ball bearing	462	Plug	556	Gasket
124	Retaining ring	462A	Sealing washer	601	Valve cover
124A	Support ring	473	Grease nipple	602	Sealing washer
202	Idler rotor	473A	Grease nipple cover	605	O-ring
359	Distance washer	480	Valve housing	608	Valve spindle
359A	Support ring	5010	Front cover	608A	Retaining ring
401	Pump body	502	Tension pin	612	Set screw
424	Sleeve	502A	Plug	614	Valve piston
424A	Washer	506	Gasket	615	Valve spring
429	Spindle	509	Shaft seal		

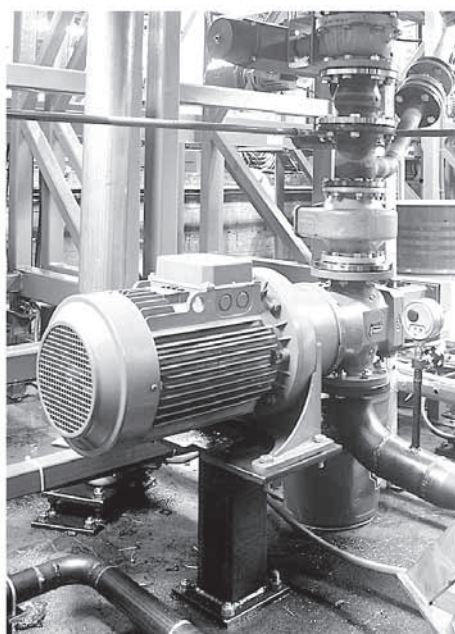

Fig. 4 Pump handling additives for lube oil production

Installation

The ACG pump is designed to be flange-mounted to its electric motor via a connecting frame and a flexible shaft coupling and has an angle bracket for mounting horizontally, vertically or any other attitude to fit the pipe connections. As standard the pump is delivered with the discharge to the left when seen from the pump rear end (see fig. 5).

On request the pump can be delivered in the opposite direction (see fig. 6).

For more information about installation read the Installation and Service instruction for ACG pumps.

*Mounting: M93-0
Standard*

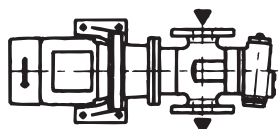

Fig. 5

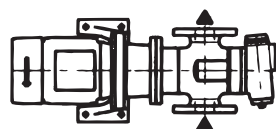

Fig. 6

Mounting: M39-0

Accessories

A bare shaft pump (Fig 7) can be ordered with the accessories in fig. 8-12.



Fig. 7 Bare shaft pump



Fig. 8 Two sets of counter flanges



Fig. 9 Connecting frame



Fig. 10 Electric motor



Fig. 11 Shaft coupling



Fig. 12 Angle bracket

Maintenance and Service

Spare parts for these pumps are easily available from stock. For detailed information and know-how about service read the Service & Installation manual for ACG pumps or contact your IMO-representative.



A Member of the
COLFAX PUMP GROUP

www.imo.se

IMO AB:

P. O. Box 42090, SE 126 14 Stockholm, Sweden

Telephone: P46 8 50 622 800, Telefax: P46 8 645 1509